



ICAO

Doc 9157

Aerodrome Design Manual

Part 1 — Runways
Fourth Edition, 2020



Approved by and published under the authority of the Secretary General

INTERNATIONAL CIVIL AVIATION ORGANIZATION



| ICAO

Doc 9157

Aerodrome Design Manual

Part 1 — Runways
Fourth Edition, 2020

Approved by and published under the authority of the Secretary General

INTERNATIONAL CIVIL AVIATION ORGANIZATION

Published in separate English, Arabic, Chinese, French, Russian
and Spanish editions by the
INTERNATIONAL CIVIL AVIATION ORGANIZATION
999 Robert-Bourassa Boulevard, Montréal, Quebec, Canada H3C 5H7

For ordering information and for a complete listing of sales agents
and booksellers, please go to the ICAO website at www.icao.int

Third edition, 2006
Fourth edition, 2020

Doc 9157, *Aerodrome Design Manual — Part 1, Runways*

Order Number: 9157P1

ISBN 978-92-9265-232-6

© ICAO 2020

All rights reserved. No part of this publication may be reproduced, stored in a
retrieval system or transmitted in any form or by any means, without prior
permission in writing from the International Civil Aviation Organization.

FOREWORD

Since the publication of the 3rd edition of this Manual in 2006, the Standards and Recommended Practices (SARPs) in Annex 14, *Aerodromes*, Volume I — *Aerodrome Design and Operations* germane to physical characteristics of aerodromes had undergone several cycles of amendments. Much of the guidance material included herein reproduces and is closely associated with the latest SARPs contained in the Annex. They are intended to facilitate the uniform application of those specifications related to the geometric design of runways and associated aerodrome elements, namely, runway shoulders, runway strips, runway end safety areas, clearways and stopways.

Modern and well-equipped aircraft have increased capabilities obtained by advanced technologies, often providing very precise trajectories on landing/take-off. Amendment 14 to Annex 14, Volume I, reduced, among others, the runway width from 60 m to 45 m for aeroplanes with an outer main gear wheel span (OMGWS) from 9 m up to but not including 15 m. This reduction is based on actual landing deviation studies of code F aeroplanes, which have demonstrated that the standard deviation from the centre line of a 45 m wide runway is less than what was assumed previously. Together with improved specifications related to runway shoulders and runway strips, these result in a more efficient use of land surface, particularly at aerodromes where real estate is at a premium.

Another significant milestone in this edition is the revised methodology for determining the aerodrome reference code for determining the numerous specifications concerning the characteristics of aerodromes. Amendment 14 decorrelated the current two code letter components, i.e. wingspan and OMGWS. since it is observed that while wingspan is relevant for aerodrome characteristics related to separation distances (e.g. obstacles, strips), the OMGWS impacts mainly ground-based manoeuvring characteristics (e.g. runway and taxiway widths). It is recognized that the two components should be used separately, since using the most demanding component may cause overdesign, either for separations or runway/taxiway width for some aeroplane types.

Existing Appendices related to aeroplane classification and runway turnpads have been updated, and a new Appendix providing guidance on performance and compatibility requirements for aircraft arresting systems has been added.

It is intended that this manual be kept current. Future editions will improve on this edition on the basis of experience gained, and of comments and suggestions received from users of the manual. Readers are therefore invited to send their views, comments and suggestions on this edition, in writing, to the Secretary General of ICAO.

Table of Contents

	<i>Page</i>
Chapter 1. General.....	1-1
1.1 Introduction.....	1-1
1.2 Explanation of terms.....	1-1
1.3 Aerodrome reference code.....	1-2
Chapter 2. Configuration considerations	2-1
2.1 Factors relating to the siting, orientation and number of runways	2-1
2.2 Location of threshold	2-5
Chapter 3. Runway length considerations	3-1
3.1 Factors affecting the length of runways.....	3-1
3.2 Actual length of runways	3-1
3.3 Runways with stopways and/or clearways	3-2
3.4 Calculation of declared distances.....	3-2
3.5 Runway length corrections for elevation, temperature and slope	3-4
Chapter 4. Aeroplane performance parameters affecting runway length	4-1
4.1 Operational terms.....	4-1
4.2 Take-off length requirement	4-1
4.3 Landing length requirement.....	4-4
Chapter 5. Physical characteristics	5-1
5.1 Runways.....	5-1
5.2 Runway shoulders.....	5-7
5.3 Runway strips.....	5-12
5.4 Runway end safety areas.....	5-16
5.5 Clearways.....	5-19
5.6 Stopways.....	5-20
Chapter 6. Planning to accommodate future aircraft developments	6-1
6.1 General.....	6-1
6.2 Future aircraft trends	6-1
6.3 Aerodrome data.....	6-1
Appendix 1. Aeroplane classification by code number and letter	App 1-1
Appendix 2. The effect of variable runway slopes on take-off runway lengths	App 2-1

Appendix 3. Aeroplane performance curves and tables for runway planning purposes..... App 3-1

Appendix 4. Runway turn pads App 4-1

Appendix 5. Aircraft arresting systems App 5-1

Chapter 1

GENERAL

1.1 INTRODUCTION

1.1.1 In view of the vital function of runways in providing for safe and efficient aircraft landings and take-offs, it is imperative that their design take into account the operational and physical characteristics of the aeroplanes expected to use the runway, as well as engineering and economic considerations.

1.1.2 The aerodrome elements associated with runways which are directly related to the landing and take-off of aeroplanes are: runway strips, runway shoulders, stopways, clearways and runway end safety areas. This manual concerns the provision of runways and these associated elements and summarizes specifications and guidance material relating to their geometric design. Pavement strength design aspects are covered in the *Aerodrome Design Manual* (Doc 9157), Part 3 — *Pavements*.

1.2 EXPLANATION OF TERMS

Aerodrome. A defined area on land or water (including any buildings, installations and equipment) intended to be used either wholly or in part for the arrival, departure and surface movement of aircraft.

Aerodrome elevation. The elevation of the highest point of the landing area.

Clearway. A defined rectangular area on the ground or water under the control of the appropriate authority, selected or prepared as a suitable area over which an aeroplane may make a portion of its initial climb to a specified height.

Displaced threshold. A threshold not located at the extremity of a runway.

Frangible object. An object of low mass designed to break, distort or yield on impact so as to present the minimum hazard to aircraft.

Instrument runway. One of the following types of runways intended for the operation of aircraft using instrument approach procedures:

- a) Non-precision approach runway. A runway served by visual aids and non-visual aid(s) intended for landing operations following an instrument approach operation type A and a visibility not less than 1000 m.
- b) Precision approach runway, category I. A runway served by visual aids and non-visual aid(s) intended for landing operations following an instrument approach operation type B with a decision height (DH) not lower than 60 m (200 ft) and either a visibility not less than 800 m or a runway visual range not less than 550 m.
- c) Precision approach runway, category II. A runway served by visual aids and non-visual aid(s) intended for landing operations following an instrument approach operation type B with a decision height (DH) lower than 60 m (200 ft) but not lower than 30 m (100 ft) and a runway visual range not less than 300 m.

- d) Precision approach runway, category III. A runway served by visual aids and non-visual aid(s) intended for landing operations following an instrument approach operation type B with a decision height (DH) lower than 30 m (100 ft), or no decision height and a runway visual range less than 300 m or no runway visual range limitations.

Landing area. That part of a movement area intended for the landing or take-off of aircraft.

Manoeuvring area. That part of an aerodrome to be used for the take-off, landing and taxiing of aircraft, excluding aprons.

Movement area. That part of an aerodrome to be used for the take-off, landing and taxiing of aircraft, consisting of the manoeuvring area and the apron(s).

Non-instrument runway. A runway intended for the operation of aircraft using visual approach procedures, or an instrument approach procedure to a point beyond which the approach may continue in visual meteorological conditions.

Note.— Visual meteorological conditions (VMC) are described in Chapter 3 of Annex 2.

Obstacle. All fixed (whether temporary or permanent) and mobile objects, or parts thereof, that are located on an area intended for the surface movement of aircraft or that extend above a defined surface intended to protect aircraft in flight.

Outer main gear wheel span (OMGWS). The distance between the outside edges of the main gear wheels.

Primary runway(s). Runway(s) used in preference to others whenever conditions permit.

Runway. A defined rectangular area on a land aerodrome prepared for the landing and take-off of aircraft.

Runway end safety area (RESA). An area symmetrical about the extended runway centre line and adjacent to the end of the strip primarily intended to reduce the risk of damage to an aeroplane undershooting or overrunning the runway.

Runway strip. A defined area including the runway and stopway, if provided, intended:

- a) to reduce the risk of damage to aircraft running off a runway; and
- b) to protect aircraft flying over it during take-off or landing operations.

Shoulder. An area adjacent to the edge of a pavement so prepared as to provide a transition between the pavement and the adjacent surface.

Threshold. The beginning of that portion of the runway usable for landing.

1.3 AERODROME REFERENCE CODE

1.3.1 The intent of the reference code is to provide a simple method for interrelating the numerous specifications concerning the characteristics of aerodromes so as to provide a series of aerodrome facilities that are suitable for the aeroplanes that are intended to operate at the aerodrome. The code is composed of two elements which are related to the aeroplane performance characteristics and dimensions. Element 1 is a number based on the aeroplane reference field length and element 2 is a letter based on the aeroplane wing span.

1.3.2 A particular specification is related to the more appropriate of the two elements of the code or to an appropriate combination of the two code elements. The code letter or number within an element selected for design purposes is related to the critical aeroplane characteristics for which the facility is provided. When applying the relevant specifications in Annex 14, Volume I, the aeroplanes which the aerodrome is intended to serve are first identified and then the two elements of the code.

1.3.3 An aerodrome reference code — code number and letter — which is selected for aerodrome planning purposes shall be determined in accordance with the characteristics of the aeroplane for which an aerodrome facility is intended. Further, the aerodrome reference code numbers and letters shall have the meanings assigned to them in Table 1-1. A classification of representative aeroplanes by the code number and code letter is included in Appendix 1.

1.3.4 The code number for element 1 shall be determined from Table 1-1, selecting the code number corresponding to the highest value of the aeroplane reference field lengths of the aeroplanes for which the runway is intended. The aeroplane reference field length is defined as the minimum field length required for take-off at maximum certificated take-off mass, sea level, standard atmospheric conditions, still air and zero runway slope, as shown in the appropriate aeroplane flight manual prescribed by the certifying authority or equivalent data from the aeroplane manufacturer. Accordingly, if 1 650 m corresponds to the highest value of the aeroplane reference field lengths, the code number selected would be '3'.

1.3.5 The code letter for element 2 shall be determined from Table 1-1 by selecting the code letter which corresponds to the greatest wing span of the aeroplanes for which the facility is intended.

1.3.6 The wingspan is relevant for aerodrome characteristics related to separation distances (e.g. obstacles, strips), while OMGWS impacts ground-based manoeuvring characteristics (e.g. runway and taxiway widths). The two components should be used separately, since using the most demanding component may cause overdesign, either for separations or runway/taxiway width for some aeroplane types. As the OMGWS is the relevant parameter for determining runway width and taxiway width, it is referenced directly in the relevant provisions to avoid the complexity of a third code element.

Table 1-1. Aerodrome reference code

Code element 1	
Code number	Aeroplane reference field length
1	Less than 800 m
2	800 m up to but not including 1 200 m
3	1 200 m up to but not including 1 800 m
4	1 800 m and over
Code element 2	
Code letter	Wingspan
A	Up to but not including 15 m
B	15 m up to but not including 24 m
C	24 m up to but not including 36 m
D	36 m up to but not including 52 m
E	52 m up to but not including 65 m
F	65 m up to but not including 80 m

Note 1.— Guidance on planning for aeroplanes with wingspans greater than 80 m is given in the Aerodrome Design Manual (Doc 9157), Parts 1 and 2.

Note 2.— Procedures on conducting aerodrome compatibility study to accommodate aeroplanes with folding wing tips spanning two code letters are given in the Procedures for Air Navigation Services Aerodromes (PANS-Aerodromes, Doc 9981). Further guidance can be found in the manufacturer's aircraft characteristics for airport planning manual.

Chapter 2

CONFIGURATION CONSIDERATIONS

2.1 FACTORS RELATING TO THE SITING, ORIENTATION AND NUMBER OF RUNWAYS

General

Note.— Flexibility to accommodate any future expansion of the runway infrastructure is fundamental to the planning and design of airports.

2.1.1 Many factors affect the determination of the siting, orientation and number of runways. The more important factors are:

- a) weather, in particular the runway/aerodrome usability factor, as determined by wind distribution, and the occurrence of localized fogs;
- b) topography of the aerodrome site and its surroundings;
- c) type and amount of air traffic to be served, including air traffic control aspects;
- d) aeroplane performance considerations; and
- e) environmental considerations, particularly noise.

2.1.2 The primary runway, to the extent other factors permit, should be oriented in the direction of the prevailing wind. All runways should be oriented so that approach and departure areas are free of obstacles and, preferably, so that aircraft are not directed over populated areas.

2.1.3 The number of runways must be sufficient to meet air traffic demands, which consist of the number of aircraft arrivals and departures, and the mixture of aircraft types, to be accommodated during the busiest periods. The decision as to the total number of runways to be provided should also take into account the aerodrome usability factor and economic considerations. Guidance concerning the airport planning process including traffic forecasting and planning criteria is available in *Airport Planning Manual* (Doc 9184), Part 1 — *Master Planning*.

Type of operation

2.1.4 Particular attention should be paid to whether the aerodrome is to be used in all meteorological conditions or only in visual meteorological conditions, and whether it is intended for use by day and night or only by day.

2.1.5 When a new instrument runway is being located, particular attention needs to be given to areas over which aeroplanes will be required to fly when following instrument approach and missed approach procedures, so as to ensure that obstacles in these areas or other factors will not restrict the operation of the aeroplanes for which the runway is intended.

Wind

2.1.6 The number and orientation of runways at an aerodrome should be such that the usability factor of the aerodrome is not less than 95 per cent for the aeroplane that the aerodrome is intended to serve.

2.1.7 In the application of the 95 per cent usability factor it should be assumed that landing or take-off of aeroplanes is, in normal circumstances, precluded when the cross-wind component exceeds:

- a) 37 km/h (20 kt) in the case of aeroplanes whose reference field length is 1 500 m or over, except that when poor runway braking action owing to an insufficient longitudinal coefficient of friction is experienced with some frequency, a cross-wind component not exceeding 24 km/h (13 kt) should be assumed;
- b) 24 km/h (13 kt) in the case of aeroplanes whose reference field length is 1 200 m or up to but not including 1 500 m; and
- c) 19 km/h (10 kt) in the case of aeroplanes whose reference field length is less than 1 200 m.

2.1.8 The selection of data to be used for the calculation of the usability factor should be based on reliable wind distribution statistics that extend over as long a period as possible, preferably of not less than five years. The observations used should be made at least eight times daily and spaced at equal intervals of time, and should take into account the following:

- a) wind statistics used for the calculation of the usability factor are normally available in ranges of speed and direction, and the accuracy of the results obtained depends, to a large extent, on the assumed distribution of observations within these ranges. In the absence of any sure information as to the true distribution, it is usual to assume a uniform distribution since, in relation to the most favourable runway orientations, this generally results in a slightly conservative figure for the usability factor;
- b) the maximum mean cross-wind components given in 2.1.7 refer to normal circumstances. There are some factors which may require that a reduction of those maximum values be taken into account at a particular aerodrome. These include:
 - 1) the wide variations which may exist, in handling characteristics and maximum permissible cross-wind components, among diverse types of aeroplanes (including future types) within each of the three groups given in 2.1.7;
 - 2) prevalence and nature of gusts;
 - 3) prevalence and nature of turbulence;
 - 4) the availability of a secondary runway;
 - 5) the width of runways;
 - 6) the runway surface conditions – water, snow, slush and ice on the runway materially reduce the allowable cross-wind component; and
 - 7) the strength of the wind associated with the limiting cross-wind component.

2.1.9 The 95 per cent criterion recommended by Annex 14, Volume I is applicable to all conditions of weather; nevertheless, it is useful to examine wind speed and direction for different visibility conditions. Weather records can usually

be obtained from government weather bureaus. The velocities are generally grouped into 22.5 degree increments (16 points of the compass). The weather records contain the percentage of time certain combinations of ceiling and visibility occur (e.g. ceiling, 500 to 274 m; visibility, 4.8 to 9.7 km), and the percentage of time winds of a specific velocity occur from different directions; for example NNE, 2.6 to 4.6 kt. The directions are relative to true north. Often wind data for a new location have not been recorded. If that is the case, records of nearby measuring stations should be consulted. If the surrounding area is fairly level, the records of these stations should indicate the winds at the site of the proposed aerodrome. However, if the terrain is hilly, the wind pattern often is dictated by the topography, and it is dangerous to utilize the records of stations some distance from the site. In that event, a study of the topography of the region and consultation with local residents may prove useful but a wind study of the site should be initiated. Such a study would involve the installation of wind gauges and the keeping of wind records. Guidance material on the preparation and analysis of wind data for aerodrome planning purposes is given in the *Airport Planning Manual* (Doc 9184) Part 1 — *Master Planning*.

Visibility conditions

2.1.10 Wind characteristics under poor visibility conditions are often quite different from those experienced under good visibility conditions. Therefore a study should be made of the wind conditions occurring with poor visibility and/or low cloud base at the aerodrome, including the frequency of occurrence and the accompanying wind direction and speed.

Topography of the aerodrome site, its approaches and surroundings

2.1.11 The topographical features of the aerodrome and its surroundings should be examined. In particular the following should be reviewed:

- a) compliance with the obstacle limitation surfaces;
- b) current and future land use. The orientation and layout should be selected so as to protect as far as possible the particularly sensitive areas such as residential, school and hospital zones from the discomfort caused by aircraft noise;
- c) current and future runway lengths to be provided;
- d) construction costs; and
- e) the possibility of installing suitable non-visual and visual aids for approach-to-land.

Air traffic in the vicinity of the aerodrome

2.1.12 When considering the siting of runways the following should be taken into account:

- a) proximity of other aerodromes or ATS routes;
- b) traffic density; and
- c) air traffic control and missed approach procedures.

Environmental factors

2.1.13 The effect of a particular runway alignment on wild life, the general ecology of the area, and noise-sensitive areas of communities should be considered.

2.1.14 The noise level produced by aircraft operations at and around the aerodrome is generally considered a primary environmental cost associated with the facility. Most noise exposure lies within the land area immediately beneath and adjacent to the aircraft approach and departure paths. Noise levels are generally measured through some formulation of decibel level, duration and number of occurrences. A large number of noise measuring techniques exist (see Annex 16 — *Environmental Protection and Recommended Method for Computing Noise Contours around Airports* (Cir 205)). Proper site selection and adjacent land use planning can serve to greatly reduce and possibly eliminate the noise problem associated with the aerodrome.

Parallel runways

2.1.15 The number of runways to be provided in each direction depends on the forecast of aircraft movements (see the *Airport Planning Manual* (Doc 9184), Part 1).

2.1.16 *VMC operations.* Where parallel runways are provided for simultaneous use under visual meteorological conditions only, the minimum distance between their centre lines should be:

- a) 210 m where the higher code number is 3 or 4;
- b) 150 m where the higher code number is 2; and
- c) 120 m where the higher code number is 1.

2.1.17 *IMC operations.* Where parallel runways are provided for simultaneous operations under instrument meteorological conditions (IMC), the minimum separation distance between their centre lines should be:

- a) 1 035 m for independent parallel approaches;
- b) 915 m for dependent parallel approaches;
- c) 760 m for independent parallel departures;
- d) 760 m for segregated parallel operations;

except that:

- a) for segregated parallel operations the specified separation distance:
 - 1) may be decreased by 30 m for each 150 m that the arrival runway is staggered toward the arriving aircraft, to a minimum of 300 m; and
 - 2) should be increased by 30 m for each 150 m that the arrival runway is staggered away from the arriving aircraft;
- b) lower separation distances than those specified above may be applied if, after aeronautical study, it is determined that such lower separation distances would not affect the safety of operations of aircraft.

2.1.18 Guidance on planning and conducting simultaneous operations on parallel or near-parallel instrument runways is contained in the *Manual on Simultaneous Operations on Parallel or Near-Parallel Instrument Runways (SOIR)* (Doc 9643).

Terminal area between parallel runways

2.1.19 To minimize taxi operations across active runways and to better utilize the area between the parallel runways, the terminal area and other operational areas may be placed between parallel runways. To accommodate these areas, greater separation distances than those recommended in the preceding paragraph may be required.

2.2 LOCATION OF THRESHOLD

2.2.1 The threshold is normally located at the extremity of a runway, if there are no obstacles penetrating above the approach surface. In some cases, however, due to local conditions it may be desirable to displace the threshold permanently (see 2.2.3). When studying the location of a threshold, consideration should also be given to the height of the ILS reference datum and the determination of the obstacle clearance limits. (Specifications concerning the height of the ILS reference datum are given in Annex 10, Volume I.)

2.2.2 In determining that no obstacle penetrates above the approach surface, account should be taken of the presence of mobile objects (vehicles on roads, trains, etc.).

2.2.3 If an object extends above the approach surface and the object cannot be removed, consideration should be given to displacing the threshold permanently.

2.2.4 To meet the obstacle limitation objectives of Annex 14, Volume I, Chapter 4, the threshold should ideally be displaced down the runway for the distance necessary to ensure that the approach surface is clear of obstacles.

2.2.5 However, displacement of the threshold from the runway extremity will inevitably cause reduction of the landing distance available, and this may be of greater operational significance than penetration of the approach surface by marked and lighted obstacles. A decision to displace the threshold, and the extent of such displacement, should therefore have regard to an optimum balance between the considerations of clear approach surfaces and adequate landing distance. In deciding this question, account will need to be taken of the types of aeroplanes which the runway is intended to serve, the limiting visibility and cloud base conditions under which the runway will be used, the position of the obstacles in relation to the threshold and extended centre line and, in the case of a precision approach runway, the significance of the obstacles to the determination of the obstacle clearance limit.

2.2.6 Notwithstanding the consideration of landing distance available, the selected position for the threshold should not be such that the obstacle-free surface to the threshold is steeper than 3.3 per cent where the code number is 4 or steeper than 5 per cent where the code number is 3.

Chapter 3

RUNWAY LENGTH CONSIDERATIONS

3.1 FACTORS AFFECTING THE LENGTH OF RUNWAYS

3.1.1 Factors which have a bearing on the runway length to be provided are:

- a) performance characteristics and operating masses of the aeroplanes to be served;
- b) weather, particularly surface wind and temperature;
- c) runway characteristics such as slope and surface condition; and
- d) aerodrome location factors, for example, aerodrome elevation which affects the barometric pressure and topographical constraints.

3.1.2 The relationship between runway length and aeroplane performance characteristics is discussed in Chapter 4. The greater the head wind down a runway, the shorter the runway length required by an aeroplane taking off or landing. Conversely, a tail wind increases the length of runway required. The higher the temperature, the longer the runway required because higher temperatures create lower air densities resulting in lower output of thrust and reduced lift. The effect of runway slopes on runway length requirements is discussed in detail in Appendix 2, however it is evident that an aeroplane taking off on an uphill gradient requires more runway length than it would on a level or downhill gradient; the specific amount depends on the elevation of the aerodrome and the temperature. All other factors being equal, the higher the elevation of the aerodrome with correspondingly lower barometric pressure, the longer the runway required. The runway length which can be provided at an aerodrome may be constrained by property boundaries or topographical features such as mountains, the sea or steep valleys.

3.2 ACTUAL LENGTH OF RUNWAYS

Primary runways

3.2.1 Except where a runway is associated with a stopway and/or clearway, the actual runway length to be provided for a primary runway should be adequate to meet the operational requirements of the aeroplanes for which the runway is intended and should be not less than the longest length determined by applying the corrections for local conditions to the operations and performance characteristics of the relevant aeroplanes.

3.2.2 Both take-off and landing requirements need to be considered when determining the length of runway to be provided and the need for operations to be conducted in both directions of the runway. Local conditions that may need to be considered include elevation, temperature, runway slope, humidity and the runway surface characteristics.

3.2.3 When performance data on aeroplanes for which the runway is intended are not known, the actual length of a primary runway may be determined by application of general correction factors as described in 3.5. However, it is advisable that the aeroplane manufacturer's document entitled Aeroplane Characteristics for Airport Planning be consulted for the most up-to-date information.

Secondary runways

3.2.4 The length of a secondary runway should be determined similarly to primary runways except that it needs only to be adequate for those aeroplanes which require to use that secondary runway in addition to the other runway or runways in order to obtain a usability factor of at least 95 per cent.

3.2.5 Flight manuals providing data on aeroplane operational requirements and performance characteristics are available for most modern aeroplanes. Aeroplane performance curves and tables for landing and take-off operations have also been developed for basic runway length planning purposes. Information on these aeroplane performance curves and tables is given in Appendix 3.

3.3 RUNWAYS WITH STOPWAYS AND/OR CLEARWAYS

3.3.1 Where a runway is associated with a stopway or clearway, an actual runway length less than that resulting from application of 3.2.2 or 3.2.3, as appropriate, may be considered satisfactory, but in such a case any combination of runway, stopway and/or clearway provided should permit compliance with the operational requirements for take-off and landing of the aeroplanes the runway is intended to serve.

3.3.2 The decision to provide a stopway and/or a clearway as an alternative to an increased length of runway will depend on the physical characteristics of the area beyond the runway end, and on the operating performance requirements of the prospective aeroplanes. The runway, stopway and clearway lengths to be provided are determined by the aeroplane take-off performance, but a check should also be made of the landing distance required by the aeroplanes using the runway to ensure that adequate runway length is provided for landing. The length of a clearway, however, cannot exceed half the length of take-off run available.

3.4 CALCULATION OF DECLARED DISTANCES

3.4.1 The introduction of stopways and clearways and the use of displaced thresholds on runways has created a need for accurate information regarding the various physical distances available and suitable for the landing and take-off of aeroplanes. For these purposes, the term "declared distances" is used with the following four distances associated with a particular runway:

- a) Take-off run available (TORA), i.e. the length of runway declared available and suitable for the ground run of an aeroplane taking off.
- b) Take-off distance available (TODA), i.e. the length of the take-off run available plus the length of the clearway, if provided.
- c) Accelerate-stop distance available (ASDA), i.e. the length of the take-off run available plus the length of the stopway, if provided.
- d) Landing distance available (LDA), i.e. the length of runway which is declared available and suitable for the ground run of an aeroplane landing.

3.4.2 Annex 14, Volume I, calls for the calculation of declared distances for a runway intended for use by international commercial air transport, and Annex 15 calls for the reporting of declared distances for each direction of the runway in the State Aeronautical Information Publication (AIP). Figure 3-1 illustrates typical cases, and Figure 3-2 shows a tabulation of declared distances.

3.4.3 Where a runway is not provided with a stopway or clearway and the threshold is located at the extremity of the runway, the four declared distances should normally be equal to the length of the runway as shown in Figure 3-1(A).

3.4.4 Where a runway is provided with a clearway (CWY), then the TODA will include the length of clearway as shown in Figure 3-1(B).

3.4.5 Where a runway is provided with a stopway (SWY), then the ASDA will include the length of stopway as shown in Figure 3-1(C).

3.4.6 Where a runway has a displaced threshold, then the LDA will be reduced by the distance the threshold is displaced as shown in Figure 3-1(D). A displaced threshold affects only the LDA for approaches made to that threshold; all declared distances for operations in the reciprocal direction are unaffected.

3.4.7 Figures 3-1B through 3-1(D) illustrate a runway provided with a clearway, a stopway or having a displaced threshold. Where more than one of these features exist then more than one of the declared distances will be modified - but the modification will follow the same principle illustrated. Figure 3-1(E) illustrates the situation where all these features exist.

3.4.8 A suggested format for providing information on declared distances is given in Figure 3-2. If a runway direction cannot be used for take-off or landing, or both, because it is operationally forbidden, then this should be declared and the words "not usable" or the abbreviation "NU" entered.

3.4.9 Where provision of a runway end safety area may involve encroachment in areas where it would be particularly prohibitive to implement, and the appropriate authority considers a runway end safety area essential, consideration may have to be given to reducing some of the declared distances.

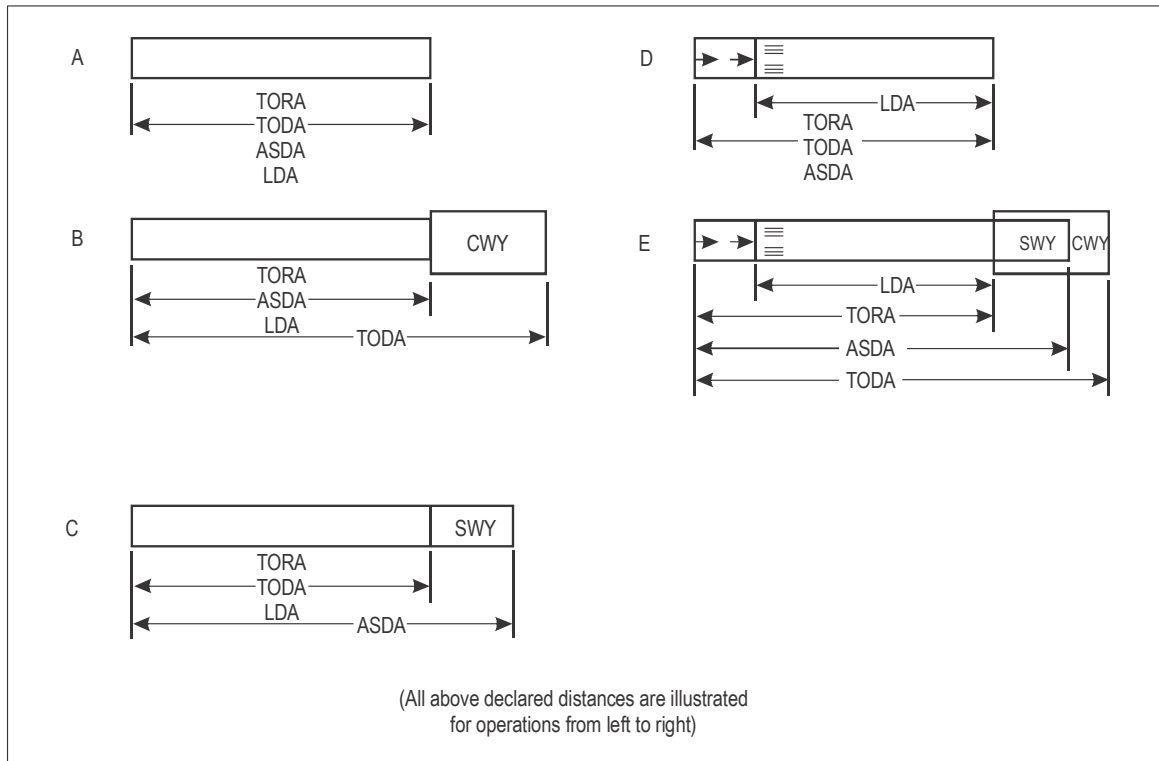

Figure 3-1. Illustration of declared distances

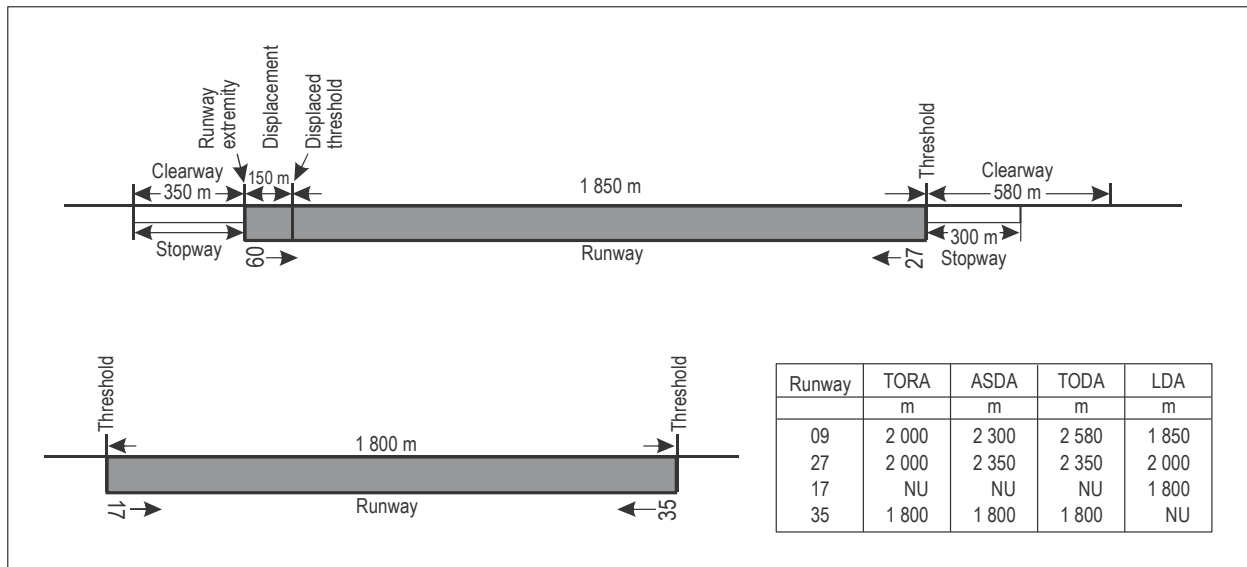

Figure 3-2. Determination of declared distances

3.5 RUNWAY LENGTH CORRECTIONS FOR ELEVATION, TEMPERATURE AND SLOPE

3.5.1 As stated in 3.2.3, when the appropriate flight manual is not available the runway length must be determined by applying general correction factors. As a first step, a basic length should be selected for the runway adequate to meet the operational requirements of the aeroplanes for which the runway is intended. This basic length is a runway length selected for aerodrome planning purposes which is required for take-off or landing under standard atmospheric conditions for zero elevation, zero wind and zero runway slope.

3.5.2 The basic length selected for the runway should be increased at the rate of 7 per cent per 300 m elevation.

3.5.3 The length of runway determined under 3.5.2 should be further increased at the rate of 1 per cent for every 1°C by which the aerodrome reference temperature exceeds the temperature in the standard atmosphere for the aerodrome elevation (see Table 3-1). If, however, the total correction for elevation and temperature exceeds 35 per cent, the required corrections should be obtained by means of a specific study. The operational characteristics of certain aeroplanes may indicate that these correction constants for elevation and temperature are not appropriate, and that they may need to be modified by results of aeronautical study based upon conditions existing at the particular site and the operating requirements of such aeroplanes.

Table 3-1. Table of Standard Atmosphere Values

Altitude (m)	Temperature (Centigrade)	Pressure (Kg/m ³)
0	15.00	1.23
500	11.75	1.17
1 000	8.50	1.11
1 500	5.25	1.06
2 000	2.00	1.01
2 500	-1.25	0.96
3 000	-4.50	0.91
3 500	-7.75	0.86
4 000	-10.98	0.82
4 500	-14.23	0.78
5 000	-17.47	0.74
5 500	-20.72	0.70
6 000	-23.96	0.66

3.5.4 The aerodrome reference temperature is the monthly mean of the average daily temperature for the hottest month of the year plus one-third of the difference between this temperature and the monthly mean of the maximum daily temperature for the same month of the year.

$$\text{Aerodrome reference temperature} = T_1 + \frac{T_2 - T_1}{3}$$

where T_1 = the monthly mean of the average daily temperature for the hottest month of the year.

where T_2 = the monthly mean of the maximum daily temperature for the same month.

The values of T_1 and T_2 are determined over a period of years. On any day, it is easy to observe the maximum and minimum temperature, t_2 and t_1 , respectively.

$$\text{Average daily temperature} = \frac{t_1 + t_2}{2}$$

$$\text{Maximum daily temperature} = t_2$$

For a thirty-day month, therefore, the monthly mean of the average daily temperature, $T_1 = \frac{1}{30}$ of the thirty values of $\frac{t_1 + t_2}{2}$

obtained once every day in the hottest month, all added together. Similarly, the monthly mean of the maximum daily

temperature $T_2 = \frac{1}{30}$ of the thirty values of t_2 obtained once every day in the hottest month, all added together.

3.5.5 Where the basic length determined by take-off requirements is 900 m or over, that length should be further increased at the rate of 10 per cent for each 1 per cent of the runway slope as defined in 5.1.4.

3.5.6 At aerodromes where temperature and humidity are both high, some addition to the runway length determined under 3.5.5 may be necessary, even though it is not possible to give exact figures for the increased length required.

Examples of the application of runway length corrections

3.5.7 The following examples illustrate the application of the runway length corrections.

Example 1:

a) Data:

- | | |
|--|----------|
| 1) runway length required for landing at sea level in standard atmospheric conditions | 2 100 m |
| 2) runway length required for take-off at a level site at sea level in standard atmospheric conditions | 1 700 m |
| 3) aerodrome elevation | 150 m |
| 4) aerodrome reference temperature | 24°C |
| 5) temperature in the standard atmosphere for 150 m | 14.025°C |
| 6) runway slope | 0.5% |

b) Corrections to runway take-off length:

- | | |
|---|---------|
| 1) runway take-off length corrected for elevation =
$\left[1700 \times 0.07 \times \frac{150}{300}\right] + 1700 =$ | 1 760 m |
| 2) runway take-off length corrected for elevation and temperature =
$[1760 \times (24 - 14.025) \times 0.01] + 1760 =$ | 1 936 m |
| 3) runway take-off length corrected for elevation, temperature and slope =
$[1936 \times 0.5 \times 0.10] + 1936 =$ | 2 033 m |

c) Correction to runway landing length:

- | | |
|--|---------|
| runway landing length corrected for elevation =
$\left[2100 \times 0.07 \times \frac{150}{300}\right] + 2100 =$ | 2 174 m |
|--|---------|

d) Actual runway length = 2 175 m

Example 2:

a) Data:

- 1) runway length required for landing at sea level in standard atmospheric conditions 2 100 m
- 2) runway length required for take-off at a level site at sea level in standard atmospheric conditions 2 500 m
- 3) aerodrome elevation 150 m
- 4) aerodrome reference temperature 24°C
- 5) temperature in the standard atmosphere for 150 m 14.025°C
- 6) runway slope 0.5%

b) Correction to runway take-off length:

- 1) runway take-off length corrected for elevation =
 $\left[2500 \times 0.07 \times \frac{150}{300}\right] + 2500 =$ 2 588 m
- 2) runway take-off length corrected for elevation and temperature =
 $[2588 \times (24 - 14.025) \times 0.01] + 2588 =$ 2 846 m
- 3) runway take-off length corrected for elevation, temperature and slope =
 $[2846 \times 0.5 \times 0.10] + 2546 =$ 2 988 m

c) Correction to runway landing length:

runway landing length corrected for elevation =
 $\left[2100 \times 0.07 \times \frac{150}{300}\right] + 2100 =$ 2 174 m

d) Actual runway length = 2 988 m

Chapter 4

AEROPLANE PERFORMANCE PARAMETERS AFFECTING RUNWAY LENGTH

4.1 OPERATIONAL TERMS

Before discussing the relationship between aeroplane performance parameters and runway length requirements it is necessary to explain the following operational terms:

- a) *Decision speed* (V_1) is the speed chosen by the operator at which the pilot, having recognized a failure of the critical engine, decides whether to continue the flight or initiate the application of the first retarding device. If the engine failure occurs before the decision speed is reached, the pilot should stop; if failure occurs later, the pilot should not stop but should continue the take-off. As a general rule a decision speed is selected which is lower, or at most equal, to the take-off safety speed (V_2). It should however exceed the lowest speed at which the aeroplane can still be controlled on or near the ground in the case of failure of the most critical engine; this speed may be given in the aeroplane flight manual.
- b) *Take-off safety speed* (V_2) is the minimum speed at which the pilot is allowed to climb after attaining a height of 10.7 m (35 ft) to maintain at least the minimum required climb gradient above the take-off surface during a take-off with one engine inoperative.
- c) *Rotation speed* (V_R) is the speed at which the pilot initiates rotation of the aeroplane to cause raising of the landing gear.
- d) *Lift-off speed* (V_{LOF}) in terms of calibrated airspeed, is the speed at which the aeroplane first becomes airborne.

4.2 TAKE-OFF LENGTH REQUIREMENT

4.2.1 The aeroplane performance operating limitations require a length which is enough to ensure that the aeroplane can, after starting a take-off, either be brought safely to a stop or complete the take-off safely. For the purpose of discussion it is supposed that the runway, stopway and clearway lengths provided at the aerodrome are only just adequate for the aeroplane requiring the longest take-off and accelerate-stop distances, taking into account its take-off mass, runway characteristics and ambient atmospheric conditions. Under these circumstances, there is for each take-off, a speed, called the decision speed (V_1); below this speed, the take-off must be abandoned if an engine fails, while above it the take-off must be completed. A very long take-off run and take-off distance would be required to complete a take-off when an engine fails before the decision speed is reached because of the insufficient speed and the reduced power available. There would be no difficulty in stopping in the remaining accelerate-stop distance available provided action is taken immediately. In these circumstances the correct course of action would be to abandon the take-off.

4.2.2 On the other hand, if an engine fails after the decision speed is reached, the aeroplane will have sufficient speed and power available to complete the take-off safely in the remaining take-off distance available. However, because of the high speed, there would be difficulty in stopping the aeroplane in the remaining accelerate-stop distance available.

4.2.3 The decision speed is not a fixed speed for any aeroplane, but can be selected by the pilot within limits to suit the accelerate-stop and take-off distance available, aeroplane take-off mass, runway characteristics, and ambient atmospheric conditions at the aerodrome. Normally, a higher decision speed is selected as the accelerate-stop distance available increases.

4.2.4 A variety of combinations of accelerate-stop distances required and take-off distances required can be obtained to accommodate a particular aeroplane, taking into account the aeroplane take-off mass, runway characteristics, and ambient atmospheric conditions. Each combination requires its particular length of take-off run.

4.2.5 The most familiar case is where the decision speed is such that the take-off distance required is equal to the accelerate-stop distance required; this value is known as the balanced field length. Where stopway and clearway are not provided, these distances are both equal to the runway length. However, if landing distance is for the moment ignored, runway is not essential for the whole of the balanced field length, as the take-off run required is, of course, less than the balanced field length. The balanced field length can, therefore, be provided by a runway supplemented by an equal length of clearway and stopway, instead of wholly as a runway. If the runway is used for take-off in both directions, an equal length of clearway and stopway has to be provided at each runway end. The saving in runway length is, therefore, bought at the cost of a greater overall length.

4.2.6 In case economic considerations preclude the provision of stopway and, as a result only runway and clearway are to be provided, the runway length (neglecting landing requirements) should be equal to the accelerate-stop distance required or the take-off run required whichever is the greater. The take-off distance available will be the length of the runway plus the length of clearway.

4.2.7 The minimum runway length and the maximum stopway or clearway length to be provided may be determined as follows, from the data in the Aeroplane Flight Manual for the aeroplane considered to be critical from the viewpoint of runway length requirements:

- a) if a stopway is economically possible, the lengths to be provided are those for the balanced field length. The runway length is the take-off run required or the landing distance required, whichever is the greater. If the accelerate-stop distance required is greater than the runway length so determined, the excess may be provided as stopway, usually at each end of the runway. In addition, a clearway of the same length as the stopway must also be provided;
- b) if a stopway is not to be provided, the runway length is the landing distance required, or if it is greater, the accelerate-stop distance required which corresponds to the lowest practical value of the decision speed. The excess of the take-off distance required over the runway length may be provided as clearway, usually at each end of the runway.

4.2.8 In addition to the above consideration, the concept of clearways in certain circumstances can be applied to a situation where the take-off distance required for all engines operating exceeds that required for the engine failure case.

4.2.9 The economy of a stopway can be entirely lost if, after each usage, it must be regraded and compacted. Therefore, it should be designed to withstand at least a certain number of loadings of the aeroplane which the stopway is intended to serve without inducing structural damage to the aeroplane.

4.2.10 Taking as a schematic illustration (Figure 4-1 (a)) the case of an aeroplane standing at the entrance end A of a runway, the pilot starts the take-off, the aeroplane accelerates and approaches the decision speed (V_1) point B. A sudden and complete failure of an engine is assumed to occur and is recognized by the pilot as the decision speed (V_1) is attained. The pilot can either:

- a) brake until the aeroplane comes to a standstill at point Y (the accelerate-stop distance); or

- b) continue accelerating until reaching the rotation speed (V_R), point C, at which time the aeroplane rotates and becomes airborne at the lift-off speed (V_{LOF}), point D, after which it reaches the end of the take-off run, point X, and continues to the 10.7 m (35 ft) height at the end of the take-off distance, point Z.

4.2.11 Figure 4-1 (b) illustrates a normal all-engines operating case where d'_1 and d'_3 are similar to d_1 and d_3 , respectively, in Figure 4-1 (a).

4.2.12 The engine-inoperative take-off and accelerate-stop distances will vary according to the selection of the decision speed (V_1). If the decision speed is reduced, the distance to point B (Figure 4-1 (a)) is reduced, as is the accelerate-stop distance; but the take-off run and take-off distances are increased as a larger part of the take-off manoeuvre is carried out with an engine inoperative. Figure 4-2 illustrates the probable relationship which may exist between the accelerate-stop distances, the take-off distances, and the take-off runs with respect to variations in the decision speed, (V_1), within the limits stated in 4.1.1.

4.2.13 The take-off performance characteristics of a given aeroplane will not necessarily encompass the range of decision speeds shown in Figure 4-2. Rather, under specified conditions, an individual aeroplane may be found to be restricted to within one of the areas indicated by the horizontal brackets a, b or c. In the case illustrated by bracket a, the take-off distance with an engine inoperative is critical. The logical selection of V_1 , point (1), would be to have it equal V_2 or V_R depending on the aeroplane's take-off characteristics. In the case illustrated by bracket b, the accelerate-stop distance is critical from the V_2 speed down to a point where ground controllability may become critical. The logical selection of V_1 would be to keep it as low as is practical, point (2). In the case illustrated by bracket c, which is the more general case, the accelerate-stop distance is critical at V_1 speeds near the V_2 speed and the take-off distance is critical at speeds near the minimum speed for controllability, in this case the V_1 speed selected is usually the optimum, i.e. the V_1 at which the two distances are equal, point (3). If the all-engines operating take-off distance is critical in one or more of the cases cited, the range of possible V_1 speeds is somewhat enlarged because that distance is independent of the V_1 speed.

4.2.14 It will be seen that the total length required is the least in the case of the optimum decision speed (V_1), and this is always true. Normally, therefore, the runway should be constructed to this length. However, the part of the accelerate-stop distance not required for the take-off run (the length B in Figure 4-3) will be used very rarely and may therefore be constructed more economically than the part A required for take-off run, i.e. the runway itself. Further, during take-off, the length B + C will only be flown over during the initial climb to the height specified in Annex 6 and is not expected to bear the mass of the aircraft; it requires only to be clear of obstacles.

4.2.15 In certain circumstances, the construction of runways with surfaces such as stopways and clearways may prove to be more advantageous than the construction of conventional runways. The choice between a solution involving a conventional runway and one in which a combination of these surfaces is used, will depend on the local physical and economic conditions, size and clearances of the site, soil characteristics, possibility of acquiring land, plans for future development, nature and cost of available materials, time interval required for carrying out the work, acceptable level of maintenance charges, etc. In particular, the construction of stopways at each end of the runway (since there are normally two directions for take-off) may frequently be an economical first stage in the extension of an existing runway. The stopways, which are not used for landings and are used by the aeroplane only in exceptional cases during take-off, can frequently be provided without considerable expenditure, and their establishment is operationally equivalent for the aeroplane to a lengthening of the runway.

4.2.16 In order to choose between the non-conventional runway and the preferred conventional runway, it is necessary to determine the proportions of clearway or clearway/stopway which may be provided. Figure 4-3 illustrates how this can be done for a particular aeroplane under one set of conditions of altitude, temperature, take-off mass, etc. As shown above, the distance for the take-off run, the take-off distance and the accelerate-stop distance for a particular aeroplane during take-off depend on the choice of the decision speed V_1 . Within a certain range (as noted in 4.1.1) any value of V_1 can be chosen and consequently many combinations of runway, stopway and clearway would appear to be possible. The minimum requirements for the design of a non-conventional runway will normally include a runway and a clearway, or a runway and a combination clearway/stopway, depending on the V_1 speeds used. This is illustrated in Figure 4-3.

4.2.17 Expansion of a conventional runway to a non-conventional runway to accommodate an increase in mass of the critical aeroplane is illustrated in Figure 4-4. In Figure 4-4 (a), the critical aeroplane uses the optimum V_1 speed, point 3, at mass W_0 on the existing runway. With the mass increased to W_1 , the optimum V_1 speed is somewhat increased, point 3'. The mass increase is limited to that which results in take-off run (d_1) equal to the length of runway. The additional take-off distance and accelerate-stop distance can be accommodated by a combination clearway/stopway. In Figure 4-4 (b), two cases are cited. In the first case, the aeroplane's V_1 speed is at point 1. The new V_1 speed, point 1', would increase if the initial climb out speed (V_2) increased due to the mass change. The mass increase is limited to that which would result in a take-off run (d_1) at mass W_1 equal to the take-off distance (d_3) at mass W_0 . The increase in take-off distance can be accommodated by a clearway. In the second case, the aeroplane's V_1 speed is at point 2. The V_1 speed, point 2', would probably be held constant. The mass increase would be limited by the increased take-off distance d_3 at mass W_1 if a clearway was not to be provided. The increase in accelerate-stop distance can be accommodated by a stopway. Note that any further increase in mass will require the use of a combined clearway/stopway. The effect caused by the all-engines-operating case can readily be seen by a comparison of Figure 4-3, (a) and (b). Lower values of V_1 are of no interest since they result in both greater take-off run and take-off distance.

4.2.18 The runway length determined from the take-off performance charts is the greater of either:

- a) the balanced field length, that is, the runway length required when the take-off distance with one engine inoperative and accelerate-stop distance are equal; or
- b) 115 per cent of the take-off distance with all engines operative.

4.3 LANDING LENGTH REQUIREMENT

Although landing lengths are normally not critical, aeroplane landing performance charts should be consulted to check that runway length requirements for take-off provide adequate runway length for landing. In general a landing length is determined that provides for an aeroplane landing after clearing all obstacles in the approach path by a safe margin and stopping safely. Allowance shall be made for variations in the approach and landing techniques of particular aeroplanes, if such allowance has not been made in the scheduling of performance data. The runway length determined from a landing performance chart is the aeroplane's landing distance required divided by 0.6. Where the length of runway required for landing is greater than that required for the take-off run, this will determine the minimum length of runway required.

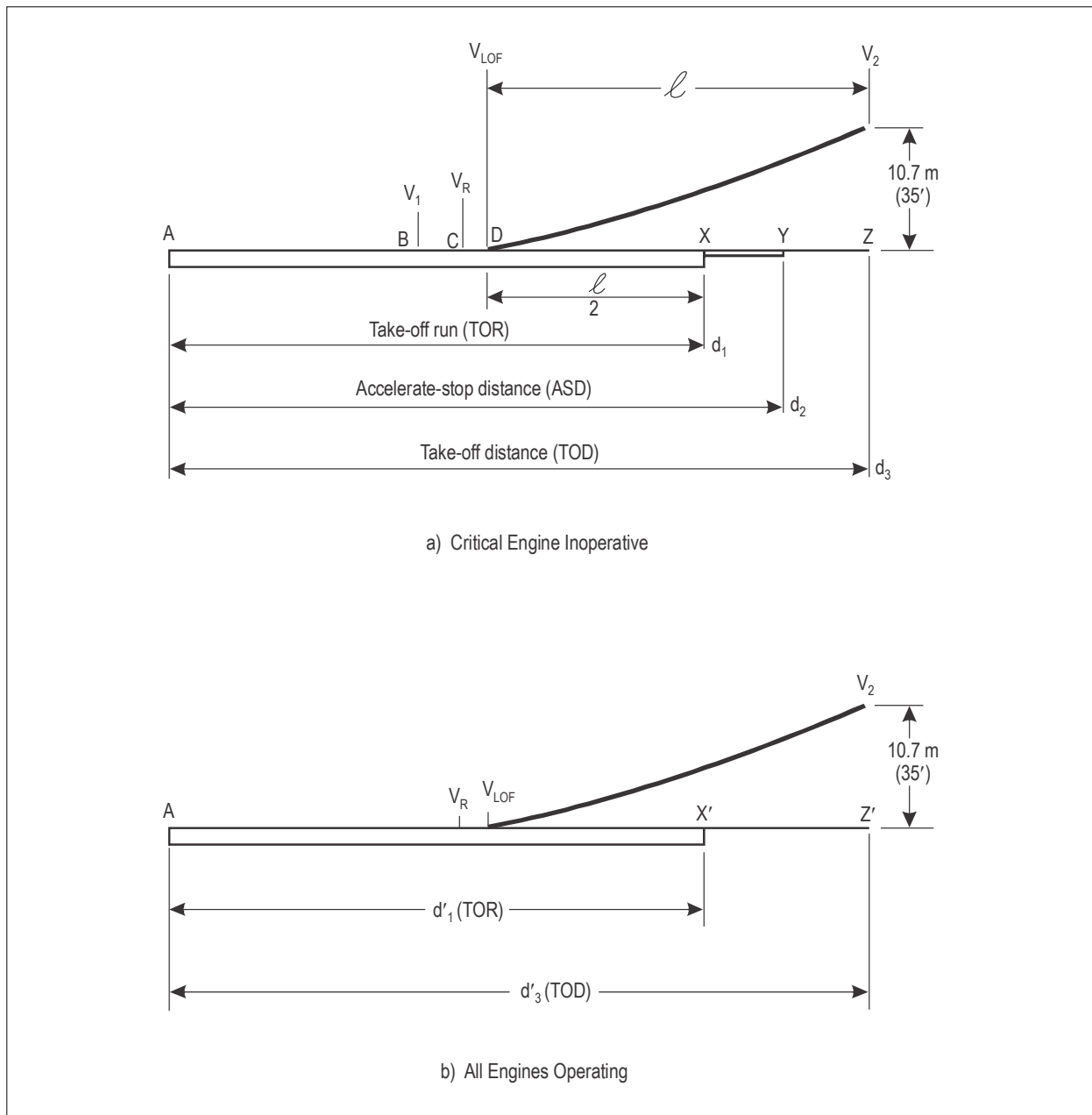

Figure 4-1.

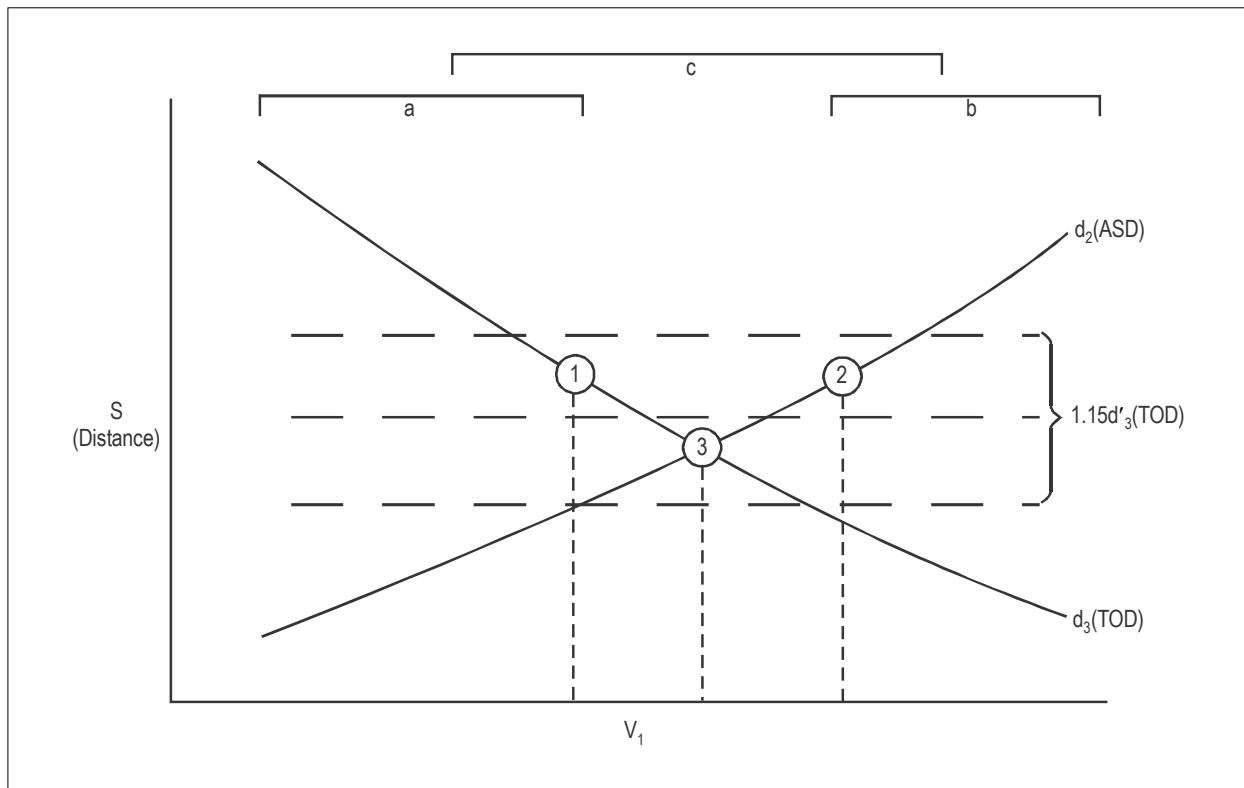

Figure 4-2.

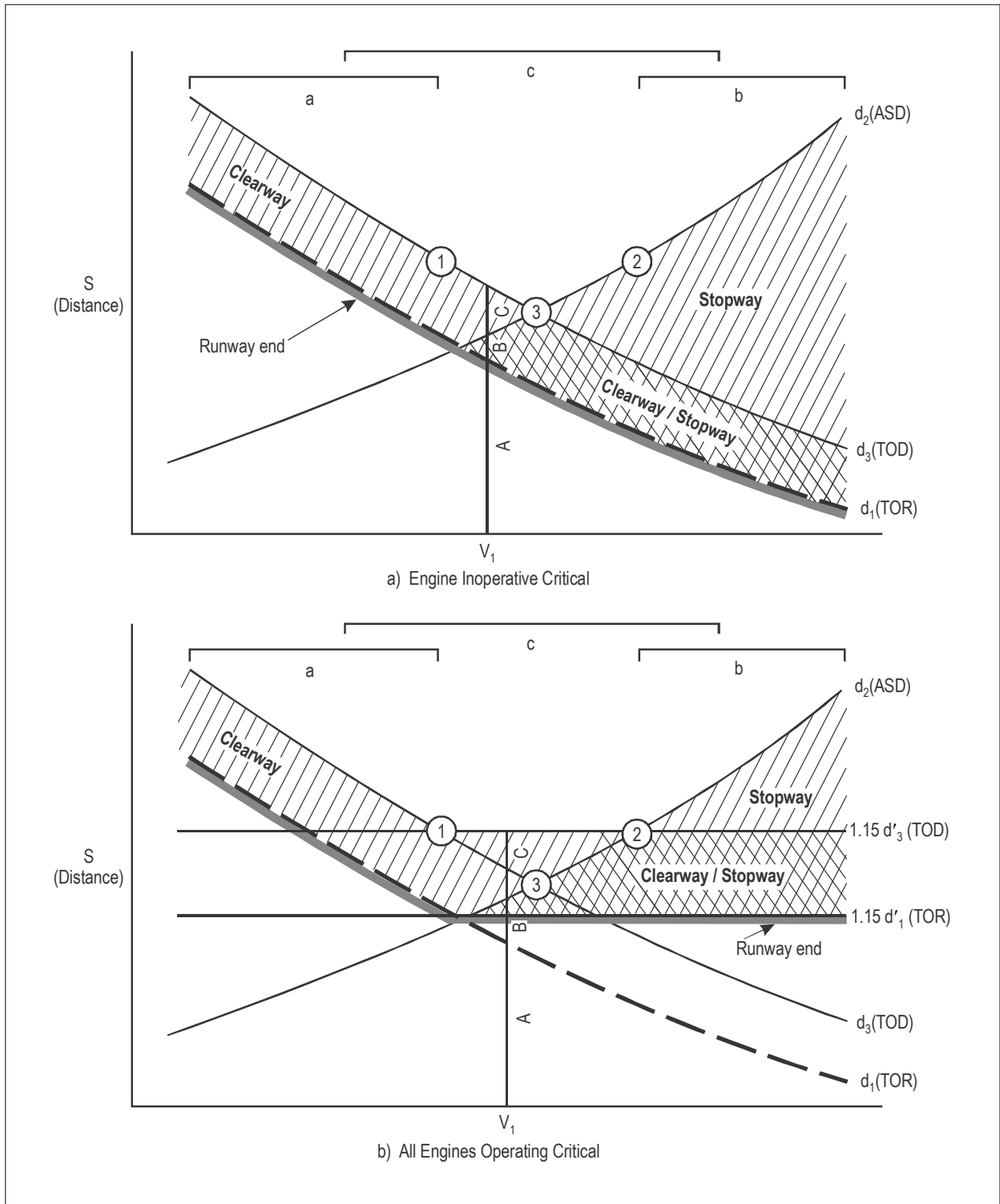

Figure 4-3.

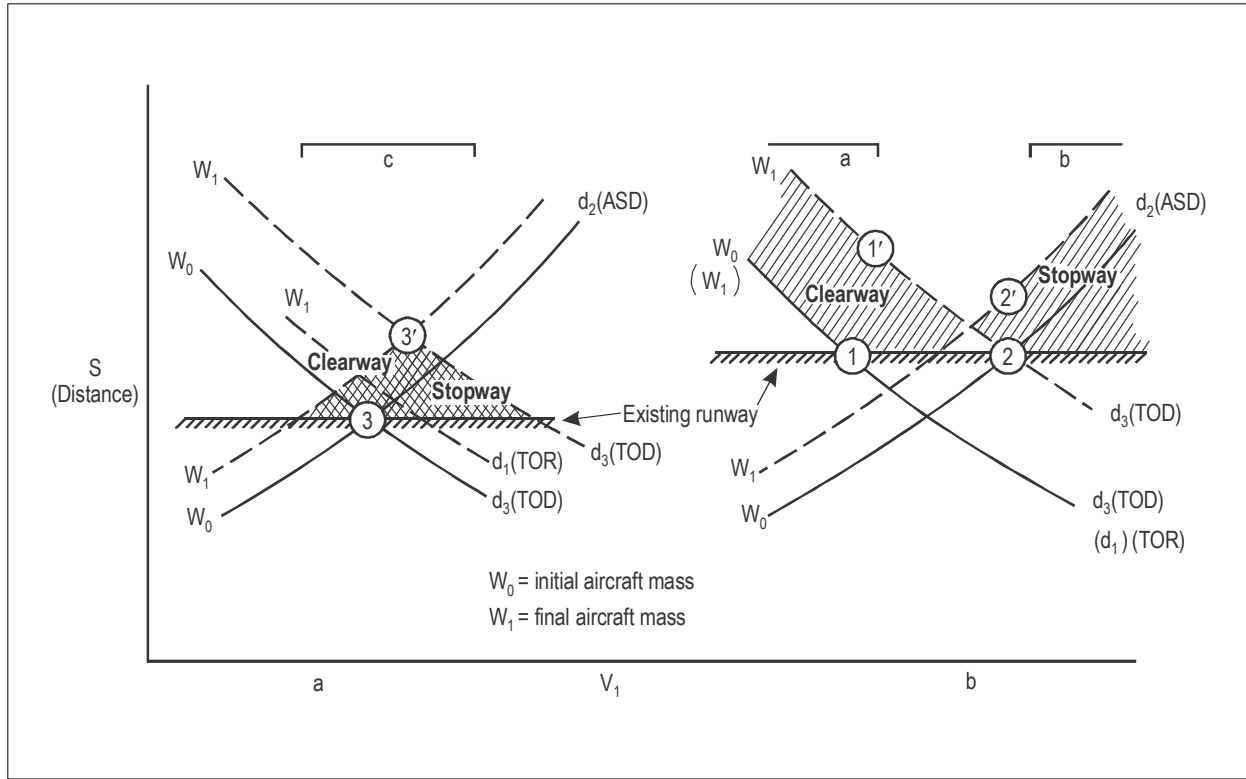

Figure 4-4.

Chapter 5

PHYSICAL CHARACTERISTICS

5.1 RUNWAYS

Width

5.1.1 The primary parameter for determining the width of a runway is the OMGWS of the aeroplane the runway is intended to serve. The width of a runway should be not less than the appropriate dimension specified in Table 5-1.

5.1.2 The runway widths shown in Table 5-1 are the minimum widths considered necessary to ensure safety of operations. The factors affecting the width of runways are:

- a) deviation of an aeroplane from the centre line at touchdown;
- b) cross-wind condition;
- c) runway surface contamination (e.g. rain, snow, slush or ice);
- d) rubber deposits;
- e) crab landing approaches used in cross-wind conditions;
- f) approach speeds used;
- g) visibility; and
- h) Human Factors.

Table 5-1. Runway widths

Code number	Outer Main Gear Wheel Span (OMGWS)			
	Up to but not including 4.5 m	4.5 m up to but not including 6 m	6 m up to but not including 9 m	9 m up to but not including 15 m
1 ^a	18 m	18 m	23 m	–
2 ^a	23 m	23 m	30 m	–
3	30 m	30 m	30 m	45 m
4	–	–	45 m	45 m

a. The width of a precision approach runway should be not less than 30 m where the code number is 1 or 2.

5.1.3 Simulator studies of aborted take-offs on contaminated runways, with one engine failure and in cross-wind conditions, and through actual observation at many airports, indicate that the specified runway width for each aerodrome reference code is operationally required. Should aircraft operations be planned on runways with lesser widths than specified above, the consequent impact on safety, efficiency and regularity of operations and on airport capacity must be studied.

Longitudinal slopes

5.1.4 The slope computed by dividing the difference between the maximum and minimum elevation along the runway centre line by the runway length should not exceed:

- a) 1 per cent where the code number is 3 or 4; and
- b) 2 per cent where the code number is 1 or 2.

5.1.5 Along no portion of a runway should the longitudinal slope exceed:

- a) 1.25 per cent where the code number is 4, except that for the first and last quarter of the length of the runway the longitudinal slope should not exceed 0.8 per cent;
- b) 1.5 per cent where the code number is 3, except that for the first and last quarter of the length of a precision approach runway category II or III the longitudinal slope should not exceed 0.8 per cent; and
- c) 2 per cent where the code number is 1 or 2.

Longitudinal slope changes

5.1.6 Where slope changes cannot be avoided, a slope change between two consecutive slopes should not exceed:

- a) 1.5 per cent where the code number is 3 or 4; and
- b) 2 per cent where the code number is 1 or 2.

5.1.7 The transition from one slope to another should be accomplished by a curved surface with a rate of change not exceeding:

- a) 0.1 per cent per 30 m (minimum radius of curvature of 30 000 m) where the code number is 4;
- b) 0.2 per cent per 30 m (minimum radius of curvature of 15 000 m) where the code number is 3; and
- c) 0.4 per cent per 30 m (minimum radius of curvature of 7 500 m) where the code number is 1 or 2.

Sight distance

5.1.8 Where slope changes cannot be avoided, they should be such that there will be an unobstructed line of sight from:

- a) any point 3 m above a runway to all other points 3 m above the runway within a distance of at least half the length of the runway where the code letter is C, D or E;
- b) any point 2 m above a runway to all other points 2 m above the runway within a distance of at least half the length of the runway where the code letter is B; and
- c) any point 1.5 m above a runway to all other points 1.5 m above the runway within a distance of at least half the length of the runway where the code letter is A.

5.1.9 Consideration will have to be given to providing an unobstructed line of sight over the entire length of a single runway where a full-length parallel taxiway is not available. Where an aerodrome has intersecting runways, additional criteria on the line of sight of the intersection area would need to be considered for operational safety. A clear line of sight between the ends of intersecting runways is recommended. Terrain needs to be graded and permanent objects need to be located so that there will be an unobstructed line of sight, as stipulated in Annex 14, Volume I, 3.1.17, from any point to any corresponding point above an intersecting runway centre line, within the runway visibility zone. The runway visibility zone is an area formed by imaginary lines connecting the two runways' visibility points, as shown in Figure 5-1. The location of each runway's visibility point is determined as follows:

- a) If the distance from the intersection of two runway centre lines to a runway end is 250 m or less, the visibility point is on the centre line of the runway end.
- b) If the distance from the intersection of the two runway centre lines to a runway end is greater than 250 m but less than 500 m, the visibility point is on the centre line 250 m from the intersection of the two runway centre lines.
- c) If the distance from the intersection of the two runway centre lines to a runway end is equal to or greater than 500 m, the visibility point is on the centre line midway between the runway end and the intersection of the centre lines.

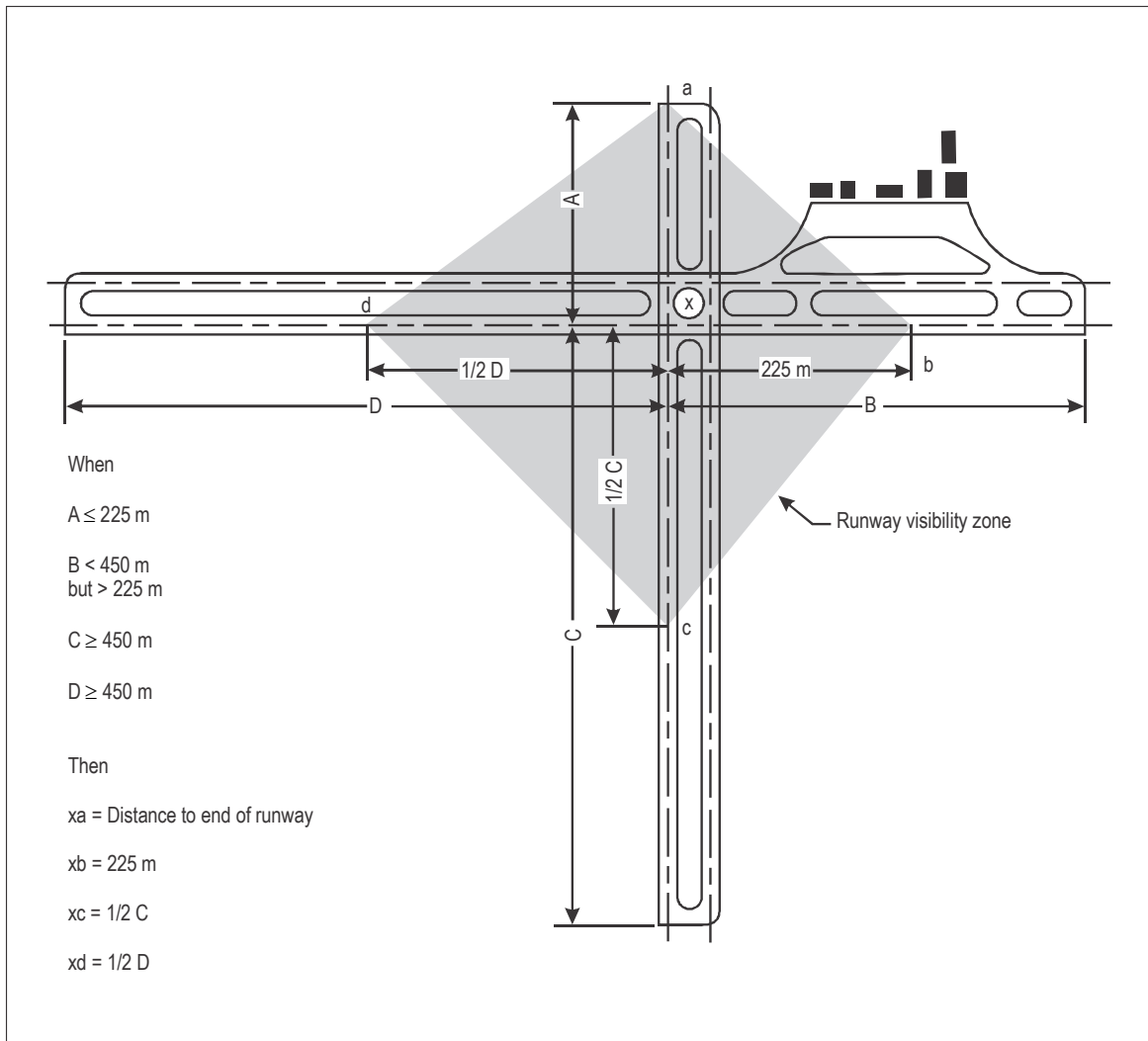

Figure 5-1. Runway visibility zone

Distance between slope changes

5.1.10 Undulations or appreciable changes in slopes located close together along a runway should be avoided. The distance between the points of intersection of two successive curves should not be less than:

- a) the sum of the absolute numerical values of the corresponding slope changes multiplied by the appropriate value as follows:
 - 1) 30 000 m where the code number is 4;
 - 2) 15 000 m where the code number is 3; and

3) 5 000 m where the code number is 1 or 2; or

b) 45 m;

whichever is greater.

5.1.11 The following example illustrates how the distance between slope changes is to be determined (see Figure 5-2):

D for a runway where the code number is 3 should be at least

$15\,000 [|x-y| + |y-z|]$ m

$|x-y|$ being the absolute numerical value of $x-y$

$|y-z|$ being the absolute numerical value of $y-z$

Assuming $x = +0.01$

$y = -0.005$

$z = +0.005$

then $|x-y| = 0.015$

$|y-z| = 0.01$

To comply with the specifications, D should be not less than:

$15\,000 (0.015 + 0.01)$ m,

that is, $15\,000 \times 0.025 = 375$ m

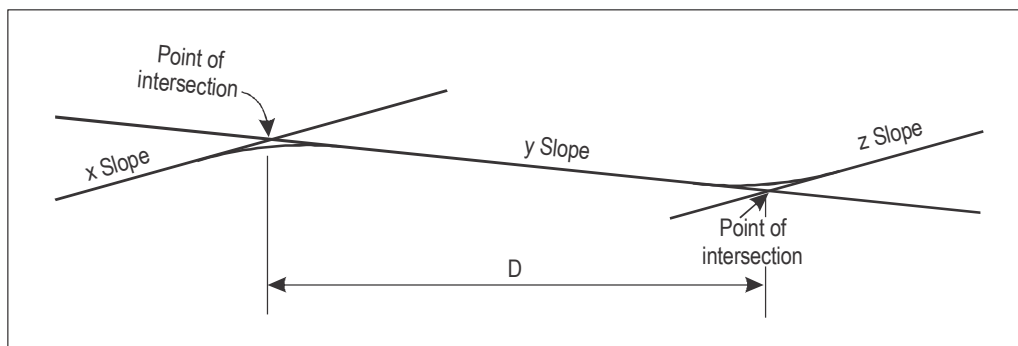

Figure 5-2. Profile on centre line of runway

Transverse slopes

5.1.12 To promote the most rapid drainage of water, the runway surface should, if practicable, be cambered except where a single crossfall from high to low in the direction of the wind most frequently associated with rain would ensure rapid drainage. The transverse slope should ideally be:

- a) 1.5 per cent where the code letter is C, D, E or F;
- b) 2 per cent where the code letter is A or B;

but in any event should not exceed 1.5 per cent or 2 per cent, as applicable, nor be less than 1 per cent except at runway or taxiway intersections where flatter slopes may be necessary. For a cambered surface the transverse slope on each side of the centre line should be symmetrical. On wet runways with cross-wind conditions the problem of aquaplaning from poor drainage is apt to be accentuated.

5.1.13 The transverse slope should be substantially the same throughout the length of a runway except at an intersection with another runway or a taxiway where an even transition should be provided taking account of the need for adequate drainage. Additional guidance is given in the *Aerodrome Design Manual* (Doc 9157), Part 3 — *Pavements*.

Combined slopes

5.1.14 When a runway is planned that will combine the extreme values for the longitudinal slopes and changes in slope combined with extreme transverse slopes, a study should be made to ensure that the resulting surface profile will not hamper the operation of aeroplanes.

Strength

5.1.15 A runway should be capable of withstanding the traffic of aeroplanes the runway is intended to serve. For details of pavement design methods refer to the *Aerodrome Design Manual*, Part 3.

Surface

5.1.16 The surface of a runway shall be constructed without irregularities that would result in loss in braking action or otherwise adversely affect the take-off or landing of an aeroplane. Surface irregularities may adversely affect the take-off or landing of an aeroplane by causing excessive bouncing, pitching, vibration or other difficulties in the control of an aeroplane. Additional guidance is included in the *Aerodrome Design Manual*, Part 3.

5.1.17 In adopting tolerances for runway surface irregularities, the following standard of construction is achievable for short distances of 3 m and conforms to good engineering practice:

Except across the crown of a camber or across drainage channels, the finished surface of the wearing course is to be of such regularity that, when tested with a 3 m straight-edge placed anywhere in any direction on the surface, there is no deviation greater than 3 mm between the bottom of the straight-edge and the surface of the pavement anywhere along the straight-edge.

5.1.18 Caution should also be exercised when inserting runway lights or drainage grilles in runway surfaces to ensure that adequate smoothness of the surface is maintained.

5.1.19 The operation of aircraft and differential settlement of surface foundations will eventually lead to increases in surface irregularities. Small deviations in the above tolerances will not seriously hamper aircraft operations. In general, isolated irregularities of the order of 2.5 cm to 3 cm over a 45 m distance are tolerable. Exact guidance on the maximum acceptable irregularity cannot be given as it varies between aircraft and, even for a certain type of aircraft, depends upon its mass, mass distribution, undercarriage characteristics and speed. A sequence of wave-like runway surface irregularities, each separately being considered acceptable, could potentially induce great dynamic loads on the aircraft undercarriage or severe vibrations which could impair the readability of the cockpit instruments.

5.1.20 The dynamic loads on an aircraft during the landing or take-off run on an uneven runway surface can be determined by measuring the actual response of an aircraft rolling over that surface. Tests by one State have shown that use of a ground-run simulation model to determine the forces acting on an aircraft undercarriage when rolling over an actually measured or planned surface profile results in a very useful tool for objectively judging the quality of a runway or taxiway surface. With this method the effects of modifications of the surface on aircraft response can be analysed before those modifications have been carried out, thus eliminating many uncertainties about the results, and the modifications to be proposed can be assessed from a cost-benefit point of view. In the simulation model, acceptability of surface unevenness is related to the loads acting on the undercarriage of the aircraft which are considered critical for this purpose.

5.1.21 Deformation of the runway with time may also increase the possibility of the formation of water pools. Pools as shallow as approximately 3 mm in depth, particularly if they are located where they are likely to be encountered at high speed by landing aeroplanes, can induce aquaplaning which can then be sustained on a wet runway by a much shallower depth of water. It is, of course, especially necessary to prevent pools from forming whenever there is a possibility that they might become frozen.

Surface texture

5.1.22 The surface of a paved runway shall be so constructed as to provide good friction characteristics when the runway is wet. Evaluation and operational experience have shown that properly engineered and maintained asphaltic or portland cement concrete surfaces meet these criteria. This does not preclude the use of other materials which meet these criteria.

5.1.23 Measurements of the friction characteristics of a new or resurfaced runway should be made with a continuous friction measuring device using self-wetting features in order to assure that the design objectives with respect to its friction characteristics have been achieved. Guidance on friction characteristics of new runway surfaces is given in the *Airport Services Manual* (Doc 9137), Part 2 — *Pavement Surface Conditions*.

5.1.24 When the surface is grooved or scored, the grooves or scorings should be either perpendicular to the runway centre line or parallel to non-perpendicular transverse joints, where applicable. Guidance on methods for improving the runway surface texture is given in the *Aerodrome Design Manual*, Part 3 — *Pavements*.

5.2 RUNWAY SHOULDERS

General

5.2.1 Runway shoulders must be provided to ensure a transition from the full strength pavement to the unpaved strip of the runway. The paved shoulders protect the edge of the runway pavement, contribute to the prevention of soil erosion by jet blast and mitigate foreign object damage to jet engines. Where the soil is susceptible to erosion, the width of the shoulders may be increased beyond the minimum values recommended in 5.2.8, after taking into account the exhaust velocity contours of the most demanding aircraft.

5.2.2 Runway shoulders should be provided for a runway where the code letter is D, E or F.

5.2.3 The shoulder of a runway or stopway should be prepared or constructed so as to minimize any hazard to an aeroplane running off the runway or stopway. Some guidance is given in the following paragraphs on certain special problems which may arise, and on the further question of measures to avoid the ingestion of loose stones or other objects by turbine engines.

5.2.4 In some cases, the bearing strength of the natural ground in the strip may be sufficient, without special preparation, to meet the requirements for shoulders. Where special preparation is necessary, the method used will depend on local soil conditions and the mass of the aeroplanes the runway is intended to serve. Soil tests will help in determining the best method of improvement (e.g. drainage, stabilization, surfacing, light paving). However, it would be prudent to provide shoulders of appropriate strength to meet the requirements specified in 5.2.1 and to preclude possible structural damage to an aircraft veering off the main runway pavement.

5.2.5 When designing shoulders, prevention of the ingestion of stones or other objects by turbine engines should be an important consideration. The rate of damage caused to engines from ingesting foreign objects is substantial and, therefore, a matter of continuing concern. With new larger aeroplanes equipped with more powerful engines, the problem is likely to be aggravated. Protection of the runway shoulders is therefore needed. Similarly, it should be ascertained whether the planned type of surface of the shoulder will be adequate to resist erosion from engine blast.

5.2.6 Where shoulders have been treated specially, either to provide the required bearing strength or to prevent the presence of stones or debris, difficulties may arise because of a lack of visual contrast between the runway surface and that of the adjacent strip. This difficulty can be overcome either by providing a good visual contrast in the surfacing of the runway or strip, or by providing a runway side stripe marking.

5.2.7 At airports subjected to snow and ice conditions, the problem caused by foreign object damage is particularly critical on the entire movement area. The extent to which snow/ice clearance is carried out will determine the risk level not only for foreign object damage but likewise for run-offs.

5.2.8 The runway shoulders should extend symmetrically on each side of the runway so that the overall width of the runway and its shoulders is not less than the following:

- a) 60 m where the code letter is D or E for aeroplanes with OMGWS from 9 m up to but not including 15 m;
- b) 60 m where the code letter is F for two- or three-engined aeroplanes with OMGWS from 9 m up to but not including 15 m; and
- c) 75 m where the code letter is F for four (or more)-engined aeroplanes with OMGWS from 9 m up to but not including 15 m.

Slopes

5.2.9 The surface of the shoulder that abuts the runway should be flush with the surface of the runway and its transverse downward slope should not exceed 2.5 per cent.

Strength

5.2.10 The portion of a runway shoulder between the runway edge and a distance of 30 m from the runway centre line should be prepared or constructed so as to be capable, in the event of an aeroplane running off the runway, of supporting the aeroplane without inducing structural damage to the aeroplane and of supporting ground vehicles which may operate on the shoulder.

Surface of runway shoulders

5.2.11 A runway shoulder should be prepared or constructed so as to resist erosion and the ingestion of the surface material by aeroplane engines.

5.2.12 Runway shoulders for code letter F aeroplanes should be paved to a minimum overall width of runway and shoulder of not less than 60 m.

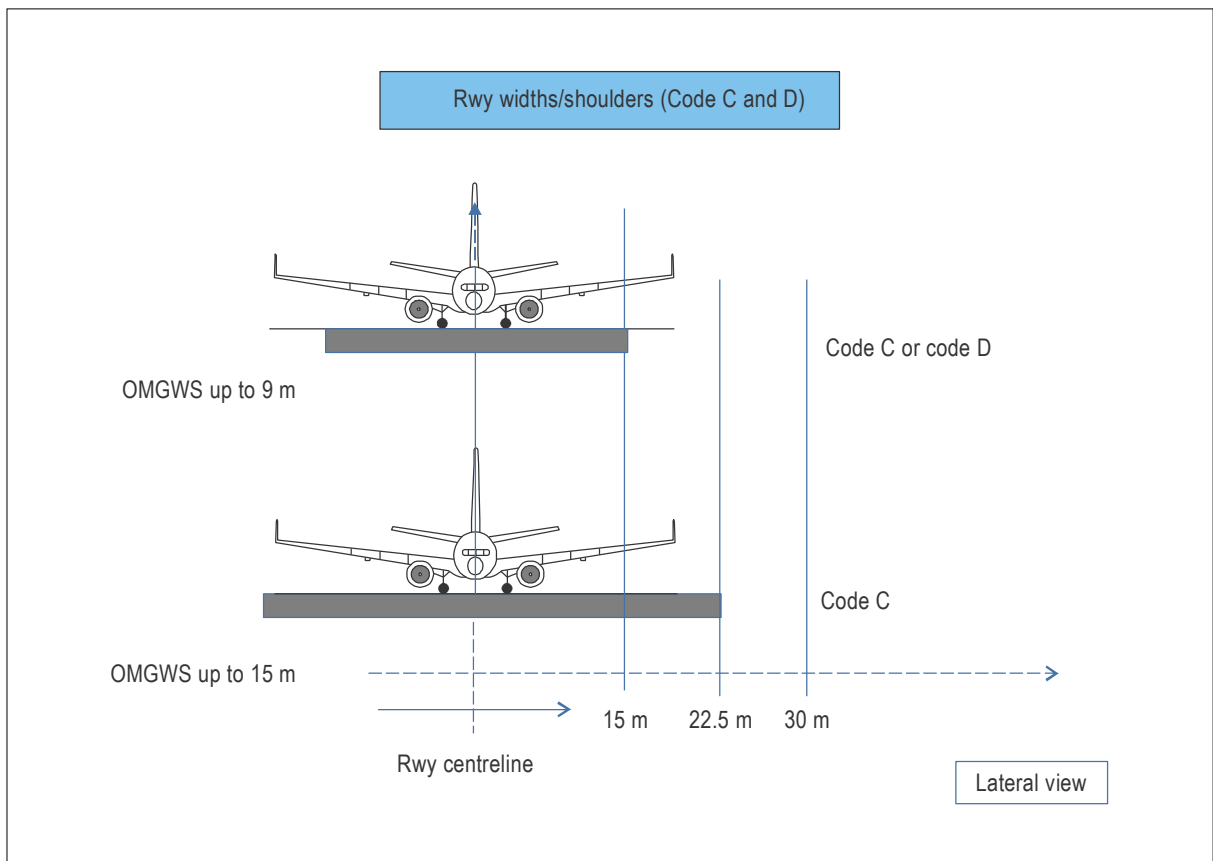

Figure 5-3 Runway width/shoulders for Codes C and D

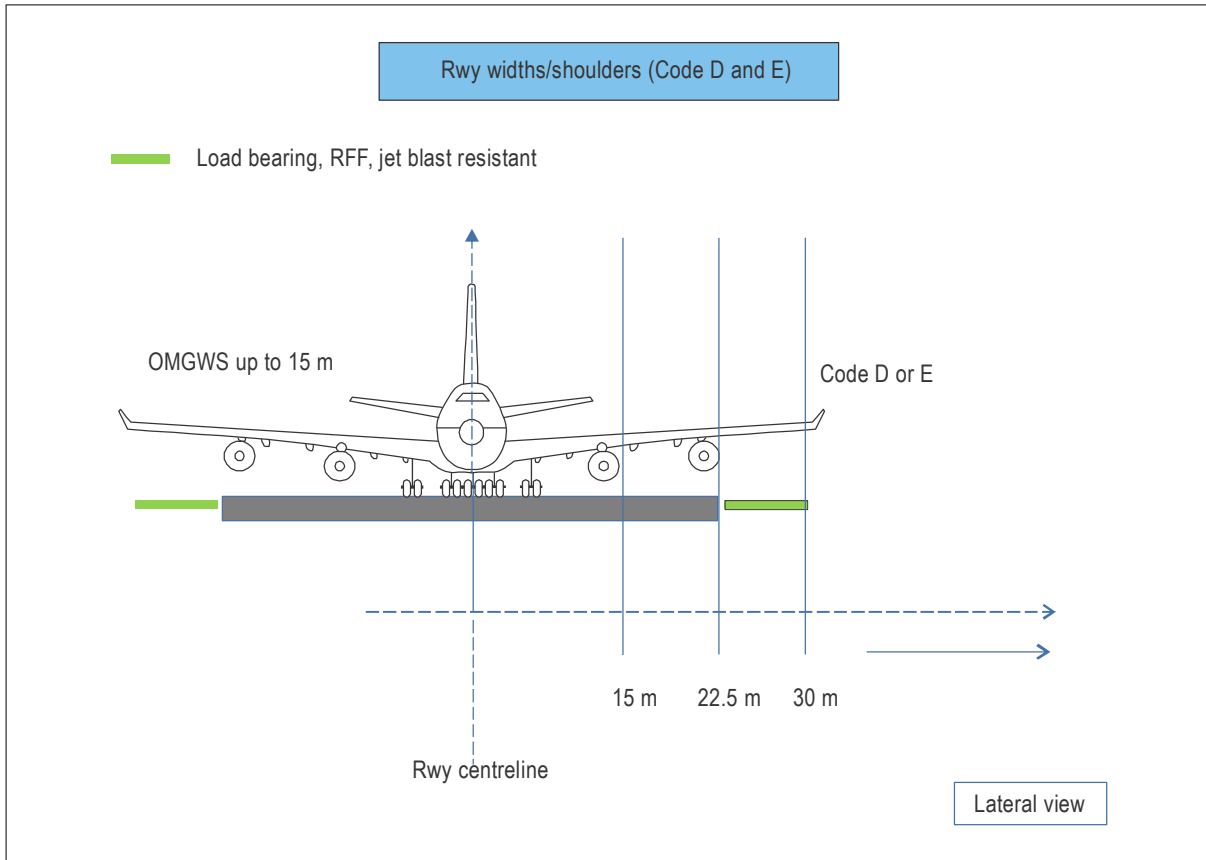

Figure 5-4. Runway width/shoulders for Codes D and E

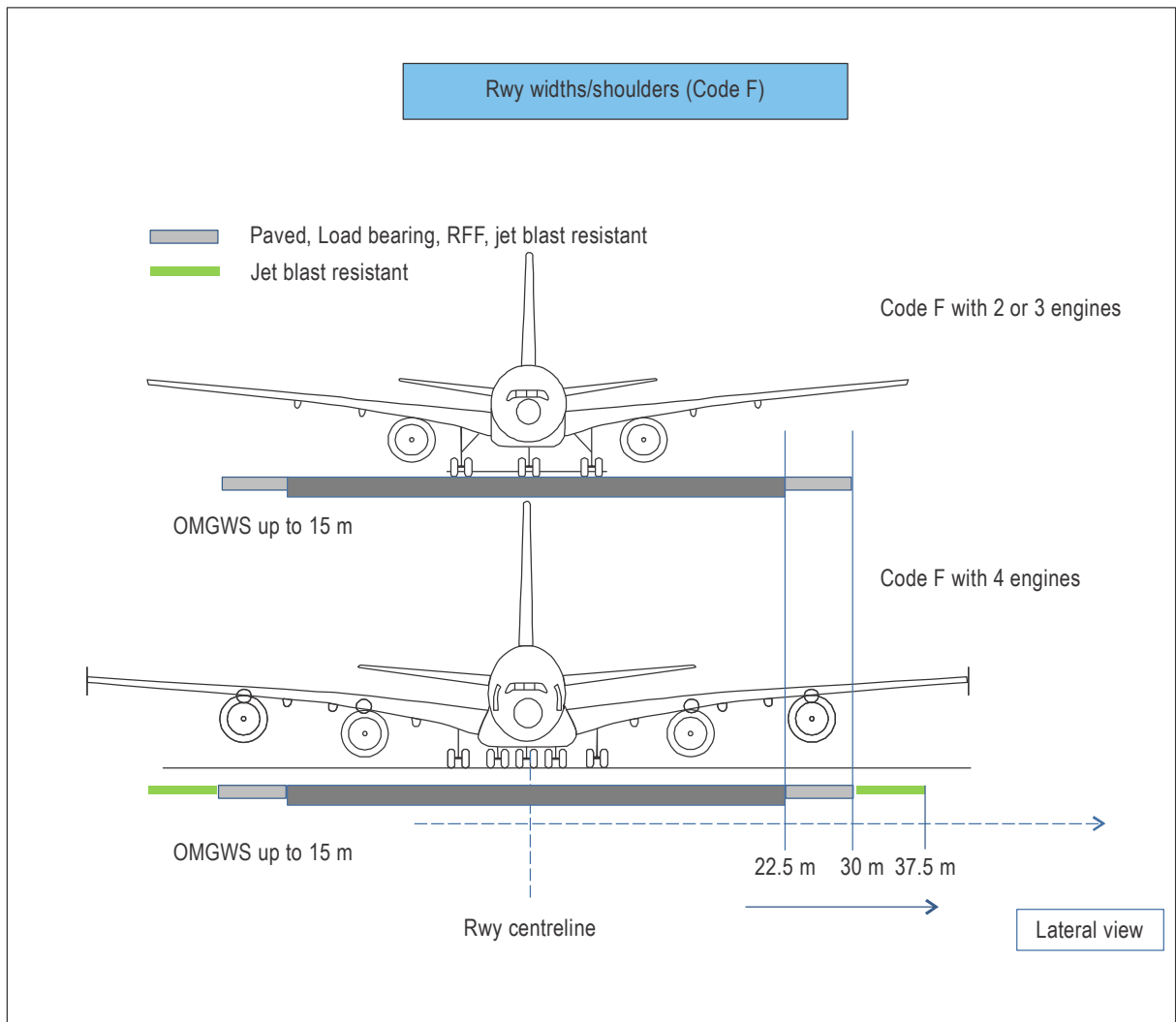

Figure 5-5. Runway width/shoulders for Code F

5.3 RUNWAY STRIPS

Purpose of a runway strip

5.3.1 A runway strip extends laterally to a specified distance from the runway centre line, longitudinally before the threshold, and beyond the runway end. It provides an area clear of objects which may endanger aeroplanes. The strip includes a graded portion which should be so prepared as to not cause the collapse of the nose gear if an aircraft should leave the runway. There are certain limitations on the slopes permissible on the graded portion of the strip. The runway strip is also required to protect ILS/MLS sensitive/critical areas. Within the strip, there is an object-free area. Any equipment or installation, required for air navigation or for aircraft safety purposes, located in this object-free area, should be frangible and mounted as low as possible. A runway and any associated stopways are included in a strip.

Length

5.3.2 A strip should extend before the threshold and beyond the end of the runway or stopway for a distance of at least:

- a) 60 m where the code number is 2, 3 or 4;
- b) 60 m where the code number is 1 and the runway is an instrument one; and
- c) 30 m where the code number is 1 and the runway is a non-instrument one.

Width

5.3.3 A strip including a precision approach runway shall, wherever practicable, extend laterally for a distance of at least:

- a) 140 m where the code number is 3 or 4; and
- b) 70 m where the code number is 1 or 2;

on each side of the centre line of the runway and its extended centre line throughout the length of the strip.

5.3.4 A strip including a non-precision approach runway should extend laterally to a distance of at least:

- a) 140 m where the code number is 3 or 4; and
- b) 70 m where the code number is 1 or 2;

on each side of the centre line of the runway and its extended centre line throughout the length of the strip.

5.3.5 A strip including a non-instrument runway should extend, on each side of the centre line of the runway and its extended centre line throughout the length of the strip, for a distance of at least:

- a) 75 m where the code number is 3 or 4;
- b) 40 m where the code number is 2; and

- c) 30 m where the code number is 1.

Objects

5.3.6 An object, other than equipment or installation required for air navigation or for aircraft safety purposes, situated on a runway strip which may endanger aeroplanes should be regarded as an obstacle and should, as far as practicable, be removed. Any equipment or installation required for air navigation or for aircraft safety purposes which must be located on the runway strip should be of minimum practicable mass and height, frangibly designed and mounted, and sited in such a manner as to reduce the hazard to aircraft to a minimum.

5.3.7 No fixed object, other than visual aids required for air navigation or those required for aircraft safety purposes and which must be sited on the runway strip, and satisfy the relevant frangibility requirement in Annex 14, Volume 1, Chapter 5, shall be permitted on any part of a runway strip of a precision approach runway delineated by the lower edges of the inner transitional surfaces.

No mobile object shall be permitted on this part of the runway strip during the use of the runway for landing or take-off.

Note.— See Annex 14, Volume 1, Chapter 4, Section 4.1 for characteristics of inner transitional surface.

5.3.8 Visual aids required for air navigation or those required for aircraft safety purposes which must be located on this part of the strip shall be of minimum practicable mass and height, frangibly designed and mounted, and sited in such a manner as to reduce the hazard to aircraft to a minimum. No mobile object shall be permitted on this part of the runway strip during the use of the runway for landing or take-off.

5.3.9 Within the general area of the strip adjacent to the runway, measures should be taken to prevent an aeroplane's wheel, when sinking into the ground, from striking a hard vertical face such as but not limited to the drainage elements in 5.3.10, as significant damage to the aircraft landing gear may result. Special problems may arise as the result of runway light fittings or other objects mounted in the strip or at the intersection with a taxiway or another runway. In the case of construction, such as runways or taxiways, where the surface must also be flush with the strip surface, a vertical face can be eliminated by chamfering from the top of the construction to not less than 30 cm below the strip surface level. Other objects, the functions of which do not require them to be at surface level, should be buried to a depth of not less than 30 cm.

5.3.10 Consideration must be given to the location and design of drains on a runway strip to prevent possible damage to an aeroplane accidentally running off a runway. Where open-air or covered storm water conveyances are installed, one must ensure that their structure does not extend above the surrounding ground in order not to be considered an obstacle.

5.3.11 Particular attention must be given to the design and maintenance of an open-air storm water conveyance in order to prevent bird attraction: if needed, it can be covered by a net. Guidance on wildlife control and reduction can be found in the *Airport Services Manual* (Doc 9137) Part 3 — *Wildlife Hazard Management*.

Grading

5.3.12 That portion of a strip of an instrument runway within a distance of at least:

- a) 75 m where the code number is 3 or 4; and
- b) 40 m where the code number is 1 or 2;

from the centre line of the runway and its extended centre line should provide a graded area for aeroplanes which the runway is intended to serve in the event of an aeroplane running off the runway.

5.3.13 For a precision approach runway it may be desirable to adopt a greater width where the code number is 3 or 4. Figure 5-6 shows the shape and dimensions of a wider strip that may be considered for such a runway. This strip has been designed using information on aircraft running off runways. The portion to be graded extends to a distance of 105 m from the centre line, except that the distance is gradually reduced to 75 m from the centre line at both ends of the strip, for a length of 150 m from the runway end.

5.3.14 That portion of a strip of a non-instrument runway within a distance of at least:

- a) 75 m where the code number is 3 or 4;
- b) 40 m where the code number is 2; and
- c) 30 m where the code number is 1;

from the centre line of the runway and its extended centre line should provide a graded area for aeroplanes which the runway is intended to serve in the event of an aeroplane running off the runway.

5.3.15 The surface of that portion of a strip that abuts a runway, shoulder or stopway shall be flush with the surface of the runway, shoulder or stopway.

5.3.16 That portion of a strip to at least 30 m before a threshold should be prepared against blast erosion in order to protect a landing aeroplane from the danger of an exposed edge.

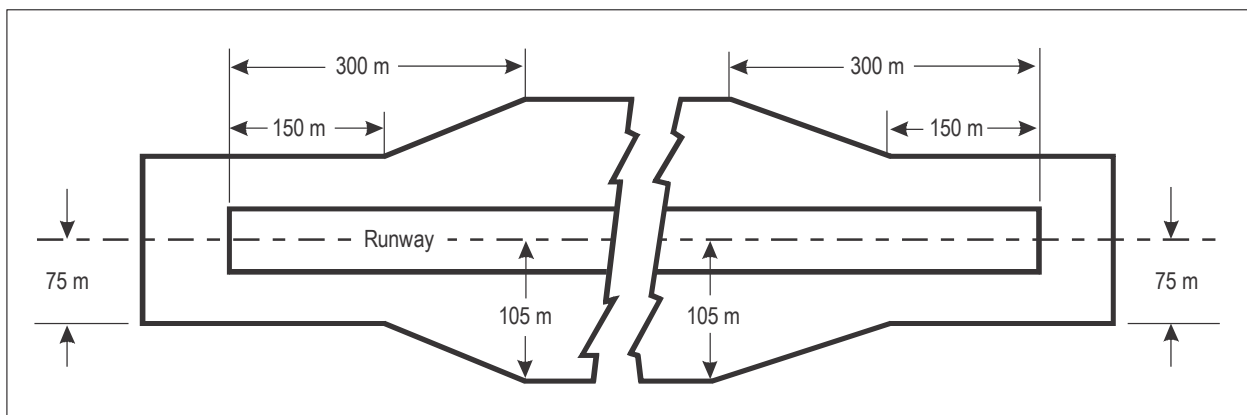

Figure 5-6. Graded portion of a strip including a precision approach runway where the code number is 3 or 4 Longitudinal slope changes

Longitudinal slopes

5.3.17 A longitudinal slope along that portion of a strip to be graded should not exceed:

- a) 1.5 per cent where the code number is 4;
- b) 1.75 per cent where the code number is 3; and
- c) 2 per cent where the code number is 1 or 2.

5.3.18 Slope changes on that portion of a strip to be graded should be as gradual as practicable and abrupt changes or sudden reversals of slopes avoided.

5.3.19 In order to accommodate aeroplanes making auto-coupled approaches and automatic landings (irrespective of weather conditions) it is desirable that slope changes before the threshold of a precision approach runway be avoided or kept to a minimum on that portion of the strip within a distance of at least 30 m on each side of the extended centre line of the runway. This is desirable because these aeroplanes are equipped with a radio altimeter for final height and flare guidance, and when the aeroplane is above the terrain immediately prior to the threshold, the radio altimeter will begin to provide information to the automatic pilot for auto-flare. Where slope changes cannot be avoided on this portion, the rate of change between two consecutive slopes should not exceed 2 per cent per 30 m.

Transverse slopes

5.3.20 Transverse slopes on that portion of a strip to be graded should be adequate to prevent the accumulation of water on the surface but should not exceed:

- a) 2.5 per cent where the code number is 3 or 4; and
- b) 3 per cent where the code number is 1 or 2;

except that to facilitate drainage the slope for the first 3 m outward from the runway, shoulder or stopway edge should be negative as measured in the direction away from the runway and may be as great as 5 per cent.

5.3.21 The transverse slopes of any portion of a strip beyond that to be graded should not exceed an upward slope of 5 per cent as measured in the direction away from the runway.

5.3.22 To minimize damage to an aircraft accidentally running off beyond the graded portion, as a matter of good practice, the transverse slopes of any portion of a strip beyond that to be graded will not exceed a downward slope of 5 per cent as measured in the direction away from the runway.

5.3.23 Where deemed necessary for proper drainage, an open-air storm water conveyance may be permitted in the non-graded portion of a runway strip. These would be placed as far as practicable from the runway. Where provided, the aerodrome rescue and firefighting procedure would need to take into account the location of such open-air water conveyances.

Strength

5.3.24 That portion of a strip of an instrument runway within a distance of at least:

- a) 75 m where the code number is 3 or 4; and
- b) 40 m where the code number is 1 or 2;

from the centre line of the runway and its extended centre line should be so prepared or constructed as to minimize hazards arising from differences in load-bearing capacity to aeroplanes which the runway is intended to serve in the event of an aeroplane running off the runway.

5.3.25 That portion of a strip containing a non-instrument runway within a distance of at least:

- a) 75 m where the code number is 3 or 4;
- b) 40 m where the code number is 2; and
- c) 30 m where the code number is 1;

from the centre line of the runway and its extended centre line should be so prepared or constructed as to minimize hazards arising from differences in load-bearing capacity to aeroplanes which the runway is intended to serve in the event of an aeroplane running off the runway.

5.3.26 Since the graded portion of a strip is provided to minimize the hazard to an aircraft running off the runway, it should be graded in such a manner as to prevent the collapse of the nose landing gear of the aircraft. The surface should be prepared in such a manner as to provide drag to an aircraft and below the surface, it should have sufficient bearing strength to avoid damage to the aircraft. To meet these divergent needs, the following guidelines are provided for preparing the strip. Aircraft manufacturers consider that a depth of 15 cm is the maximum depth to which the nose gear may sink without collapsing. Therefore, it is recommended that the soil at a depth of 15 cm below the finished strip surface be prepared to have a bearing strength of California Bearing Ratio (CBR) value of 15 to 20. The intention of this underlying prepared surface is to prevent the nose gear from sinking more than 15 cm. The top 15 cm may be of lesser strength which would facilitate deceleration of aircraft.

5.4 RUNWAY END SAFETY AREAS

Purpose of a Runway End Safety Area

5.4.1 ICAO Aircraft Accident/Incident Data Reports (ADREP) have indicated that aircraft undershooting or overrunning the runway during landings or take-offs suffer significant damage. To minimize such damage, it is considered necessary to provide an additional area beyond the ends of the runway strip. These areas, known as Runway End Safety Areas (RESA), should be capable of adequately supporting any aircraft which overruns or undershoots the runway and should be clear of all equipment and installations which are not frangible.

5.4.2 A runway end safety area is required to be provided at each end of a runway strip where:

- a) the code number is 3 or 4; and
- b) the code number is 1 or 2 and the runway is an instrument one.

5.4.3 A runway end safety area should be provided at each end of a runway strip where the code number is 1 or 2 and the runway is a non-instrument one.

Length

5.4.4 A runway end safety area is required to extend from the end of a runway strip to a distance of at least 90 m where:

- a) the code number is 3 or 4; and
- b) the code number is 1 or 2 and the runway is an instrument one.

If an arresting system is installed, the above length may be reduced, based on the design specification of the system, subject to acceptance by the State.

5.4.5 A runway end safety area should, as far as practicable, extend from the end of the runway strip to a distance of at least:

- a) 240 m where the code number is 3 or 4, or a reduced length when an arresting system is installed;
- b) 120 m where the code number is 1 or 2 and the runway is an instrument one, or a reduced length when an arresting system is installed; and
- c) 30 m where the code number is 1 or 2 and the runway is a non-instrument one.

5.4.6 When deciding the length to be provided, consideration should be given to providing an area long enough to contain overruns and undershoots resulting from a reasonably probable combination of adverse operational factors. On a precision approach runway, the ILS localizer is normally the first upstanding obstacle, and the runway end safety area should extend up to this facility. In other circumstances, the first upstanding obstacle may be a road, a railroad or other constructed or natural feature. The provision of a runway end safety area should take such obstacles into consideration.

5.4.7 A study of the ADREP data on runway overruns suggests that the standard distance of 90 m would capture approximately 61 per cent of overruns, with 83 per cent being contained within the recommended distance of 240 m. Therefore, it is recognized that some overruns would exceed the 240 m RESA distance. Accordingly, whatever length of RESA in excess of the standard is provided, it is important to ensure that the likelihood of, and potential impacts arising from, an overrun are minimized as far as reasonably practicable.

Width

5.4.8 The width of a runway end safety area is required to be at least twice that of the associated runway.

5.4.9 The width of a runway end safety area should, wherever practicable, be equal to that of the graded portion of the associated runway strip.

Objects

5.4.10 An object, other than equipment or an installation required for air navigation or for aircraft safety purposes, situated on a runway end safety area which may endanger aeroplanes should be regarded as an obstacle and should, as far as practicable, be removed. Any equipment or installation required for air navigation or for aircraft safety purposes which must be located on the runway end safety area is required to be frangible, mounted as low as possible and sited in such a manner as to reduce the hazard to aircraft to a minimum.

Clearing and grading

5.4.11 A runway end safety area should provide a cleared and graded area for aeroplanes which the runway is intended to serve in the event of an aeroplane undershooting or overrunning the runway. The surface of the ground in the runway end safety area does not need to be prepared to the same quality as the runway strip.

Combined slopes

5.4.12 The slopes of a runway end safety area should be such that no part of the runway end safety area penetrates the approach or take-off climb surface.

Longitudinal slopes

5.4.13 The longitudinal slopes of a runway end safety area should not exceed a downward slope of 5 per cent. Longitudinal slope changes should be as gradual as practicable and abrupt changes or sudden reversals of slopes avoided.

5.4.14 In order to accommodate aeroplanes making auto-coupled approaches and automatic landings (irrespective of weather conditions) it is desirable that slope changes be avoided or kept to a minimum on an area symmetrical about the extended runway centre line approximately 60 m wide, and 300 m long before the threshold of a precision approach runway. This is desirable because these aeroplanes are equipped with a radio altimeter for final height and flare guidance, and when the aeroplane is above the terrain immediately prior to the threshold, the radio altimeter will begin to provide information to the automatic pilot for auto-flare. Where slope changes cannot be avoided, the rate of change between two consecutive slopes should not exceed 2 per cent per 30 m.

Transverse slopes

5.4.15 The transverse slopes of a runway end safety area should not exceed an upward or downward slope of 5 per cent. Transitions between differing slopes should be as gradual as practicable.

Strength

5.4.16 A runway end safety area should be so prepared or constructed as to reduce the risk of damage to an aeroplane undershooting or overrunning the runway, enhance aeroplane deceleration, and facilitate the movement of rescue and fire fighting vehicles. See 5.3.26 for guidance on the minimum strength of the runway strip.

Arresting systems

5.4.17 The performance of a properly designed arresting system can be predictable and effective in arresting overruns. One such design is based on the use of engineered materials which will crush under the weight of an aeroplane, thereby absorbing energy. This type of system, known as Engineered Materials Arresting System (EMAS) has already been installed at many airports. Other types of arresting systems include the cable/hook-wire arresting system commonly installed at military airfields.

5.4.18 Several runways around the world, particularly those constructed prior to the adoption of more stringent RESA requirements in 1999, have experienced difficulties in providing a standard or recommended RESA. The most frequent causes are natural obstacles, local development and/or environmental constraints, where the costs involved in

providing the RESA may greatly outweigh the safety benefits. Amendment 11-A to Annex 14, Volume I introduced a provision that if an arresting system is installed, the length of the standard or recommended RESA may be reduced, based on the design specification of the system, subject to acceptance by the State.

5.4.19 Where provision of a runway end safety area would be particularly prohibitive to implement, consideration would have to be given to reducing some of the declared distances of the runway for the provision of a runway end safety area and installation of an arresting system. The provision of an arresting system may be an appropriate practice to increase safety since the deceleration performance of the system is mainly independent of aircraft braking performance, contamination or weather.

5.4.20 As the installation of aircraft arresting systems is subject to acceptance by the State, procedures have to be developed for analysing and accepting the installation of arresting systems in aerodromes. These procedures normally include type evaluation and in situ project acceptance of the arresting system, including maintenance programmes. However, alternative means of acceptance may be provided depending on the merits of each case.

5.4.21 Appendix 5 provides guidance on the performance and compatibility requirements for arresting systems. These requirements may be considered as an initial draft for national rules, or to be used directly as applicable provisions. A list of the national provisions of four States containing materials relevant to arresting systems is also included.

5.4.22 The presence of an arresting system shall be published in the aerodrome AIP entry and information/instructions promulgated to local runway safety teams and others to promote awareness in the pilot community. The serviceability of aircraft arresting systems is to be announced in a NOTAM (see further guidance in Doc 8126, *Aeronautical Information Services Manual*, Chapter 6 (NOTAM), Appendix B (NOTAM Selection Criteria), Category: AGA — Movement and Landing Area (M)). It is also good practice to represent the availability of arresting systems in aeronautical charts in an easily perceivable manner.

5.5 CLEARWAYS

Location

5.5.1 The origin of a clearway should be at the end of the take-off run available.

Length

5.5.2 The length of a clearway should not exceed half the length of the take-off run available.

Width

5.5.3 A clearway should extend laterally on each side of the extended centre line of the runway, to a distance of at least:

- a) 75 m for instrument runways; and
- b) half of the width of the runway strip for non-instrument runways.

Slopes

5.5.4 The ground in a clearway should not project above a plane having an upward slope of 1.25 per cent, the lower limit of this plane being a horizontal line which:

- a) is perpendicular to the vertical plane containing the runway centre line; and
- b) passes through a point located on the runway centre line at the end of the take-off run available.

5.5.5 Because of transverse or longitudinal slopes on a runway, shoulder or strip, in certain cases the lower limit of the clearway plane specified above may be below the corresponding elevation of the runway, shoulder or strip. It is not intended that these surfaces be graded to conform with the lower limit of the clearway plane nor is it intended that terrain or objects which are above the clearway plane beyond the end of the strip but below the level of the strip be removed unless it is considered they may endanger aeroplanes.

5.5.6 Abrupt upward changes in slope should be avoided when the slope on the ground in a clearway is relatively small or when the mean slope is upward. In such situations, in that portion of the clearway within a distance of 22.5 m on each side of the extended centre line, the slopes, slope changes and the transition from runway to clearway should generally conform with those of the runway with which the clearway is associated.

Objects

5.5.7 An object situated on a clearway which may endanger aeroplanes in the air should be regarded as an obstacle and should be removed. Any equipment or installation required for air navigation purposes which must be located on the clearway should be of minimum mass and height, frangibly designed and mounted, and sited in such a manner as to reduce the hazard to aircraft to a minimum.

5.6 STOPWAYS

Width

5.6.1 A stopway shall have the same width as the runway with which it is associated.

Slopes

5.6.2 Slopes and changes in slope on a stopway, and the transition from a runway to a stopway should comply with the specifications of 5.1.2 to 5.1.9 for the runway with which the stopway is associated except that:

- a) the limitation in 5.1.3 of a 0.8 per cent slope for the first and last quarter of the length of a runway need not be applied to the stopway; and
- b) at the junction of the stopway and runway and along the stopway the maximum rate of slope change may be 0.3 per cent per 30 m (minimum radius of curvature of 10 000 m) for a runway where the code number is 3 or 4.

Strength

5.6.3 A stopway should be prepared or constructed so as to be capable, in the event of an abandoned take-off, of supporting the aeroplane which the stopway is intended to serve without inducing structural damage to the aeroplane.

Surface

5.6.4 The surface of a paved stopway should be so constructed as to provide a good coefficient of friction, compatible with that of the associated runway, when the stopway is wet.

5.6.5 The friction characteristics of an unpaved stopway should not be substantially less than that of the runway with which the stopway is associated.

Chapter 6

PLANNING TO ACCOMMODATE FUTURE AIRCRAFT DEVELOPMENTS

6.1 GENERAL

6.1.1 Annex 14, Volume I, sets forth the minimum aerodrome specifications for aircraft which have the characteristics of those which are currently operating or for similar aircraft that are planned for introduction. The current specifications are therefore intended to accommodate aeroplanes up to the size of the Airbus A380-800. Accordingly, any additional safeguards that might be considered appropriate to provide for more demanding aircraft are not taken into account in the Annex. Such matters are left to appropriate authorities to evaluate and take into account as necessary for each particular aerodrome.

6.1.2 The information in the following paragraphs may assist in increasing the awareness of these authorities and airport planners of the way in which some of the specifications may alter with the introduction of larger aircraft. In this respect it is worth noting that it is probable that some increase in current maximum aircraft size will be acceptable without major modifications to existing aerodromes. However, the upper limit of aircraft size which is examined below is, in all probability, beyond this consideration unless aerodrome procedures are altered, with resulting reduction in aerodrome capacity.

6.2 FUTURE AIRCRAFT TRENDS

6.2.1 The trends for future aircraft designs may be obtained from various sources, including the aircraft manufacturers and the International Coordinating Council of Aerospace Industries Associations. For the purpose of planning future airport development, the following aircraft dimensions may be used:

	Code F	Larger than code F
wing span	up to 80 m	up to 90 m
outer main gear wheel span	up to 15 m	up to 15 m
overall length	up to 80 m	80 m or more
tail height	up to 24 m	up to 24 m
maximum gross mass	575 000 kg or more	650 000 kg or more

6.3 AERODROME DATA

6.3.1 The trend toward longer take-off distances for larger aircraft take-off masses is considered to have levelled off, and greater runway lengths than are currently available at major aerodromes should not be required.

6.3.2 Using the rationale developed for implementation of the Annex 14, Volume I, aerodrome reference code, it is possible that aircraft with larger outer main gear wheel spans could be demonstrated to operate safely on narrower runways. A value of C (equation below), no lower than the related OMGWS is considered as the minimum.

6.3.3 Runway width may be represented by the expression:

$$W_R = T_M + 2C$$

Where

T_M = outer main gear wheel span

and C = resulting clearance between the outer main gear wheel and the runway edge.

This geometry is shown in Figure 6-1.

6.3.4 A runway of 45 m width and the increased main gear wheel span of 15 m would indicate a runway edge margin of 15 m.

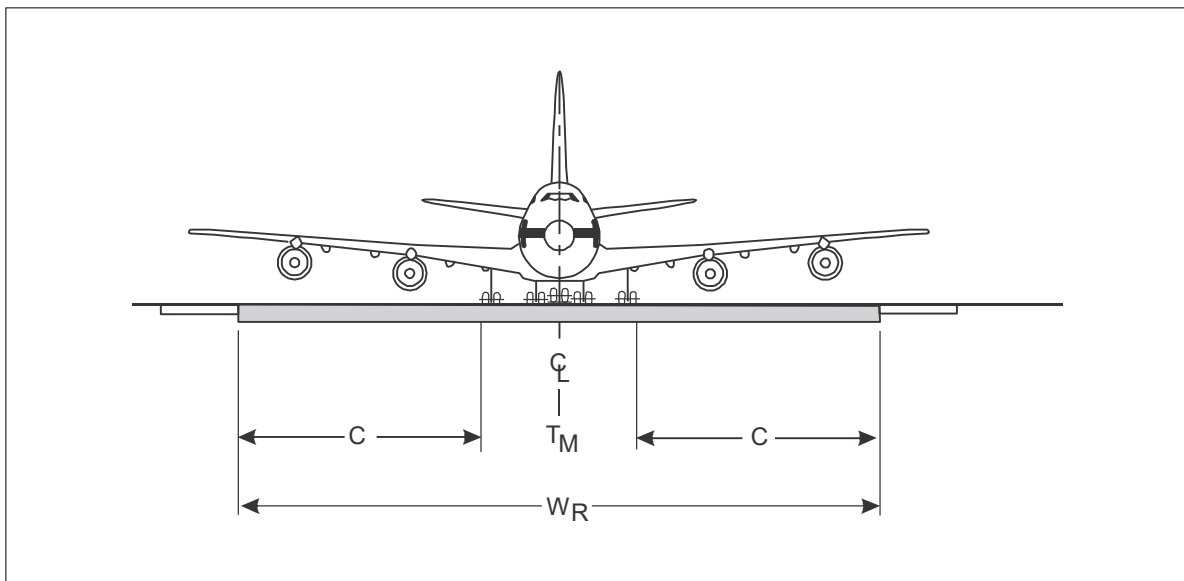

Figure 6-1. Runway width geometry

Appendix 1

AEROPLANE CLASSIFICATION BY CODE NUMBER AND LETTER

<i>Aircraft Make</i>	<i>Model</i>	<i>Code</i>	<i>Aeroplane reference field length (m)</i>	<i>Wing span (m)</i>	<i>Outer main gear wheel span (m)</i>
DeHavilland Canada	DHC2	1A	381	14.6	3.3
	DHC2T	1A	427	14.6	3.3
Britten Norman	BN2A	1A	353	14.9	4.0
Cessna	152	1A	408	10.0	—
	172 S	1A	381	11.0	2.7
	180	1A	367	10.9	—
	182 S	1A	462	11.0	2.9
	Stationair 6	1A	543	11.0	2.9
	Turbo 6	1A	500	11.0	2.9
	Stationair 7	1A	600	10.9	—
	Turbo 7	1A	567	10.9	—
	Skylane	1A	479	10.9	—
	Turbo Skylane	1A	470	10.9	—
	310	1A	518	11.3	—
	310 Turbo	1A	507	11.3	—
	Golden Eagle 421 C	1A	708	12.5	—
	Titan 404	1A	721	14.1	—
Piper	PA28-161	1A	494 ¹	10.7	3.2
	PA28-181	1A	490 ¹	10.8	3.2
	PA28R-201	1A	487 ¹	10.8	3.4
	PA32R-301	1A	539 ¹	11.0	3.5
	PA32R-301T	1A	756 ¹	11.0	3.5
	PA34-220T	1A	520 ¹	11.9	3.5

<i>Aircraft Make</i>	<i>Model</i>	<i>Code</i>	<i>Aeroplane reference field length (m)</i>	<i>Wing span (m)</i>	<i>Outer main gear wheel span (m)</i>
	PA44-180	1A	671 ¹	11.8	3.2
	PA46-350P	1A	637 ¹	13.1	3.9
Raytheon/Beechcraft	A24R	1A	603	10.0	3.9
	A36	1A	670	10.2	2.9
	76	1A	430	11.6	3.3
	B55	1A	457	11.5	2.9
	B60	1A	793	12.0	3.4
	B100	1A	579	14.0	4.3
Cessna	525	1B	939	14.3	4.1
DeHavilland Canada	DHC3	1B	497	17.7	3.7
	DHC6	1B	695	19.8	4.1
LET	L410 UPV	1B	740	19.5	4.0
Raytheon/Beechcraft	E18S	1B	753	15.0	3.9
	B80	1B	427	15.3	4.3
	C90	1B	488	15.3	4.3
	200	1B	579	16.6	5.6
Short	SC7-3/SC7-3A	1B	616	19.8	4.6
DeHavilland Canada	DHC7	1C	689	28.4	7.8
Lear Jet	24F	2A	1 005	10.9	2.5
	28/29	2A	912	13.4	2.5
Pilatus	PC-12	2B	810	16.3	4.5
	PC-24	2B	830	17.0	3.3
LET	L410 UPV-E	2B	920	20.0 ²	4.0
	L410 UPV-E9	2B	952	20.0 ²	4.0
	L410 UPV-E20	2B	1 050	20.0 ²	4.0

<i>Aircraft Make</i>	<i>Model</i>	<i>Code</i>	<i>Aeroplane reference field length (m)</i>	<i>Wing span (m)</i>	<i>Outer main gear wheel span (m)</i>
	L420	2B	920	20.0 ²	4.0
Shorts	SD3-30	2B	1 106	22.8	4.6
Dassault Aviation	Falcon 10	3A	1 615	13.1	3.0
Hawker Siddeley	HS 125-400	3A	1 646	14.3	3.3
	HS 125-600	3A	1 646	14.3	3.3
	HS 125-700	3A	1 768	14.3	3.3
Lear Jet	24D	3A	1 200	10.9	2.5
	35A/36A	3A	1 287/1 458	12.0	2.5
	54	3A	1 217	13.4	2.5
	55	3A	1 292	13.4	2.5
Bombardier Aero.	CRJ 100	3B	1 470	21.2	4.0
	CRJ 100ER	3B	1 720	21.2	4.0
	CRJ 200	3B	1 440	21.2	4.0
	CRJ 200ER	3B	1 700	21.2	4.0
Dassault Aviation	Falcon 20	3B	1 463	16.3	3.7
	Falcon 200	3B	1 700	16.3	3.5
	F50/F50EX	3B	1 586	18.9	4.5
	Falcon 900	3B	1 504	19.3	4.6
	Falcon 900EX	3B	1 590	19.3	4.6
	F2000	3B	1 658	19.3	5.0
Embraer	EMB-135 LR	3B	1 745	20.0	4.1
Fokker	F28-1000	3B	1 646	23.6	5.8
	F28-2000	3B	1 646	23.6	5.8
I.A.I.	SPX	3B	1 644	16.6	—
	Galaxy	3B	1 798	17.7	—
Gulfstream Aero.	G IV-SP	3B	1 661	23.7	4.8
Nord	262	3B	1 260	21.9	3.4

<i>Aircraft Make</i>	<i>Model</i>	<i>Code</i>	<i>Aeroplane reference field length (m)</i>	<i>Wing span (m)</i>	<i>Outer main gear wheel span (m)</i>
Antonov	AN24	3C	1 600	29.2	8.8
Airbus	A220-100	3C	1 423	35.1	6.7
	A220-300	3C	1 797	35.1	6.7
	A318-100	3C	1 779	34.1	8.9
	A319-100 w/o sharklets	3C	1 799	34.1	8.9
	A319-100 with sharklets	3C	1 799	35.8	8.9
	A319neo	3C	1 735	35.8	8.9
	A320-200 w/o sharklets ³	3C	1 797	34.1	8.9
	A320-200 with sharklets ³	3C	1 797	35.8	8.9
	A320neo	3C	1 775	35.8	8.9
Boeing	B717-200	3C	1 670	28.4	5.4
	B737-600	3C	1 690	34.3	7.0
	B737-700	3C	1 598	34.3	7.0
	B737-800 ³	3C	1 799	34.3	7.0
	B737-900 ³	3C	1 799	34.3	7.0
	B737-7 ³	3C	1 799	35.9	7.0
	B737-8 ³	3C	1 799	35.9	7.0
	B737-9 ³	3C	1 799	35.9	7.0
Convair	240	3C	1 301	28.0	8.4
	440	3C	1 564	32.1	8.6
	580	3C	1 341	32.1	8.6
	600	3C	1 378	28.0	8.4
	640	3C	1 570	32.1	8.6
Douglas	DC3	3C	1 204	28.8	5.8
	DC4	3C	1 542	35.8	8.5
	DC6A/6B	3C	1 375	35.8	8.5
	DC9-20	3C	1 551	28.5	6.0
Embraer	EMB-120 ER	3C	1 481	19.8	6.6
	EMB-170-100 STD	3C	1 431	26.0	6.3
	EMB-170-100 LR	3C	1 524	26.0	6.3

<i>Aircraft Make</i>	<i>Model</i>	<i>Code</i>	<i>Aeroplane reference field length (m)</i>	<i>Wing span (m)</i>	<i>Outer main gear wheel span (m)</i>
	EMB-170-200 LR/SU	3C	1 715	26.0	6.3
	EMB-190-100 STD	3C	1 614	28.7	7.2
	EMB-190-200 STD	3C	1 779	28.7	7.2
Fokker	F27-500	3C	1 670	29.0	7.9
	F27-600	3C	1 670	29.0	7.9
	F28-3000	3C	1 640	25.1	5.8
	F28-4000	3C	1 640	25.1	5.8
	F28-6000	3C	1 400	25.1	5.8
	F50	3C	1 355	29.0	8.0
McDonnell Douglas	MD90	3C	1 798	32.9	6.2
SAAB	340A	3C	1 220	21.4	7.3
	340B	3C	1 220	22.8 ⁴	7.3
	SAAB 2000	3C	1 340	24.8	8.9
Airbus	A300 B2	3D	1 676	44.8	10.9
Bae	ATP	3D	1 540	30.6	9.3
DeHavilland Canada	DHC5D	3D	1 471	29.3	10.2
Bombardier Aero.	CRJ 100LR	4B	1 880	21.2	4.0
	CRJ 200LR	4B	1 850	21.2	4.0
Dassault Aviation	Falcon 20-5 (Retrofit)	4B	1 859	16.3	3.7
Embraer	EMB-145 LR	4B	2 269	20.0	4.1
Airbus	A320-200 w/o sharklets	4C	2 111	34.1	8.9
	A320-200 with sharklets	4C	2 108	35.8	8.9
	A321-200 w/o sharklets	4C	2 513	34.1	8.9
	A321-200 with sharklets	4C	2 513	35.8	8.9
	A321neo	4C	2 366	35.8	8.9
BAC	1-11-200	4C	1 884	27.0	5.2

<i>Aircraft Make</i>	<i>Model</i>	<i>Code</i>	<i>Aeroplane reference field length (m)</i>	<i>Wing span (m)</i>	<i>Outer main gear wheel span (m)</i>
	1-11-300	4C	2 484	27.0	5.2
	1-11-400	4C	2 420	27.0	5.2
	1-11-475	4C	2 286	28.5	5.4
	1-11-500	4C	2 408	28.5	5.2
Boeing	B727-100	4C	2 502	32.9	6.9
	B727-200	4C	3 176	32.9	6.9
	B737-100	4C	2 499	28.4	6.4
	B737-200	4C	2 295	28.4	6.4
	B737-300	4C	2 160	28.9	6.4
	B737-400	4C	2 550	28.9	6.4
	B737-500	4C	2 470	28.9	6.4
	B737-800	4C	2 090	34.3	7.0
	B737-900	4C	2 240	34.3	7.0
	B737-7	4C	2 375	35.9	7.0
	B737-8	4C	2 600	35.9	7.0
	B737-9	4C	3 100	35.9	7.0
Embraer	EMB-170-200 STD	4C	2 221	26.0	6.3
	EMB-170-200 LR	4C	2 221	28.7	6.3
	EMB-170-200 AR	4C	2 221	26.0	6.3
	EMB-190-100 LR	4C	2 064	28.7	7.2
	EMB-190-100 IGW	4C	2 220	28.7	7.2
	EMB-190-200 LR	4C	2 179	28.7	7.2
	EMB-190-200 AR	4C	2 383	28.7	7.2
Fokker	F100	4C	1 840	28.1	6.0
Gulfstream Aero	G V	4C	1 863	28.5	5.1
Douglas	DC9-10	4C	1 975	27.2	5.9
	DC9-15	4C	1 990	27.3	6.0
	DC9-20	4C	1 560	28.4	6.0
	DC9-30	4C	2 134	28.5	5.9
	DC9-40	4C	2 091	28.5	5.9

<i>Aircraft Make</i>	<i>Model</i>	<i>Code</i>	<i>Aeroplane reference field length (m)</i>	<i>Wing span (m)</i>	<i>Outer main gear wheel span (m)</i>
	DC9-50	4C	2 451	28.5	5.9
McDonnell Douglas	MD81	4C	2 290	32.9	6.2
	MD82	4C	2 280	32.9	6.2
	MD83	4C	2 470	32.9	6.2
	MD87	4C	2 260	32.9	6.2
	MD88	4C	2 470	32.9	6.2
Airbus	A300B4-200	4D	2 727	44.8	11.1
	A300-600R	4D	2 279	44.8	11.1
	A310-300	4D	2 350	43.9	11.0
Boeing	B707-300	4D	3 088	44.4	7.9
	B707-400	4D	3 277	44.4	7.9
	B720	4D	1 981	39.9	7.5
	B757-200	4D	1 980	38.1	8.6
	B757-300	4D	2 400	38.1	8.6
	B767-200	4D	1 981	47.6	10.8
	B767-300ER	4D	2 540	47.6	10.9
	B767-400ER	4D	3 130	51.9	10.8
Canadair	CL44D-4	4D	2 240	43.4	10.5
Ilyushin	18V	4D	1 980	37.4	9.9
	62M	4D	3 280	43.2	8.0
Lockheed	L100-20	4D	1 829	40.8	4.9
	L100-30	4D	1 829	40.4	4.9
	L188	4D	2 066	30.2	10.5
	L1011-1	4D	2 426	47.3	12.8
	L1011-100/200	4D	2 469	47.3	12.8
	L1011-500	4D	2 844	47.3	12.8
Douglas	DC8-61	4D	3 048	43.4	7.5
	DC8-62	4D	3 100	45.2	7.6
	DC8-63	4D	3 179	45.2	7.6

<i>Aircraft Make</i>	<i>Model</i>	<i>Code</i>	<i>Aeroplane reference field length (m)</i>	<i>Wing span (m)</i>	<i>Outer main gear wheel span (m)</i>
	DC8-71	4D	2 770	43.4	7.5
	DC8-72	4D	2 980	45.2	7.6
	DC8-73	4D	3 050	45.2	7.6
McDonnell Douglas	DC10-10	4D	3 200	47.4	12.6
	DC10-30	4D	3 170	50.4	12.6
	DC10-40	4D	3 124	50.4	12.6
Tupolev	TU134A	4D	2 400	29.0	10.3
	TU154	4D	2 160	37.6	12.4
Airbus	A330-200	4E	2 820	60.3	12.6
	A330-300	4E	2 776	60.3	12.6
	A340-200	4E	2 891	60.3	12.6
	A340-300	4E	2 989	60.3	12.6
	A340-500	4E	3 023	63.4	12.6
	A340-600	4E	3 189	63.4	12.6
	A350-900	4E	2 631	64.7	12.9
	A350-1000	4E	2 754	64.7	12.8
Boeing	B747-100	4E	3 060	59.6	12.4
	B747-200	4E	3 150	59.6	12.4
	B747-300	4E	3 292	59.6	12.4
	B747-400	4E	2 890	64.9 ⁵	12.6
	B747-SR	4E	1 860	59.6	12.4
	B747-SP	4E	2 710	59.6	12.4
	B777-200	4E	2 390	61.0	12.9
	B777-200ER	4E	3 110	61.0	12.9
	B777-300	4E	3 140	60.9	12.9
	B777-300ER	4E	3 120	64.8	12.9
	B787-8	4E	2 600	60.1	9.8
	B787-9	4E	2 800	60.1	9.8
	B787-10	4E	2 800	60.1	9.8

<i>Aircraft Make</i>	<i>Model</i>	<i>Code</i>	<i>Aeroplane reference field length (m)</i>	<i>Wing span (m)</i>	<i>Outer main gear wheel span (m)</i>
McDonnell Douglas	MD11	4E	3 130	52.0 ⁵	12.6
Airbus	A380	4F	2 865	79.8	14.3
Boeing	B747-8	4F	2 956	68.4	12.7
	B777-9	4F	2 900 ⁶	71.8	12.8

1. Over a 15 m obstacle.
 2. With wing tip tanks installed.
 3. Alternate maximum take-off weight consult manufacture airport planning manual or airline operator.
 4. With extended wing tips.
 5. Winglets.
 6. Preliminary data.
-

Appendix 2

THE EFFECT OF VARIABLE RUNWAY SLOPES ON TAKE-OFF RUNWAY LENGTHS

1. INTRODUCTION

1.1 A study was done by the University of California, sponsored by ICAO, into the effect of variable runway slopes on take-off runway lengths. This Appendix provides a brief summary of the scope and findings of that study.

1.2 The purpose of the study was to:

- a) determine the effect of nonuniform slopes on runway lengths for a representative group of piston and jet transport aeroplanes;
- b) examine the methods used to correct for slope; and
- c) develop a correction method that best reflects the effects of non- uniform slopes.

2. AIRCRAFT SELECTED FOR STUDY

The following aircraft were selected for analysis as being representative of transport types being flown in civil aviation: DC-6B, Vanguard, DC-8 and DC-9. These aircraft encompass piston-engined propeller, turboprop, turbojet and turbofan types, respectively.

3. ASSUMPTIONS MADE FOR STUDY PURPOSES

Aerodrome elevation

3.1 Flight operation aeroplane manuals relate runway length to pressure altitude rather than to geographic elevation. Throughout the study it was assumed that the two were equivalent.

Aerodrome temperature

3.2 The temperatures used in the study were standard temperatures at the selected elevations of sea level and 300 m, and a hot day temperature of 32°C was used at both elevations.

Wind

3.3 Calm conditions were assumed to prevail on the surface of the runway.

Runway surface conditions

3.4 Runway surface irregularities and a low runway coefficient of friction were not accounted for in the study. Dry runway conditions were assumed to prevail.

Runway longitudinal slope

3.5 In considering runway longitudinal profiles to be analysed, the constraints detailed in Annex 14 at that time, i.e. the Fourth Edition, were adhered to. These were:

- a) the slope computed by dividing the difference between the maximum and minimum elevation along the runway centre line by the runway length should not exceed 1 per cent;
- b) along no portion of a runway should the longitudinal slope exceed: 1.25 per cent where the runway basic length¹ is 1 800 m or above; 1.5 per cent where the runway basic length is up to but not including 1 800 m;
- c) a slope change between two consecutive slopes should not exceed 1.5 per cent;
- d) the slope should not exceed 0.8 per cent for the first and last quarter of the length of the runway, for runways 1 800 m or above;
- e) where slope changes cannot be avoided, they should be such that there will be an unobstructed line of sight from any point 3 m above the runway to all other points 3 m above the runway within a distance of at least half the length of the runway;
- f) the transition from one slope to another should be accomplished by a curved surface with a rate of change not exceeding:
 - 1) 0.1 per cent per 30 m where the runway basic length is 1 800 m or above;
 - 2) 0.2 per cent per 30 m where the runway basic length is up to but not including 1 800 m.

Vertical curves were not used in the study profiles since their effect on runway length was considered to be negligible.

3.6 With these constraints, several study profiles were developed as shown in Figure A2-1. The profiles were grouped into four general types designated as "A", "B", "C" and "D". Type "A" profiles consist of uphill slopes; Type "B" downhill slopes; Type "C" convex profiles (uphill-downhill); and Type "D" concave profiles (downhill-uphill). The majority of the profiles shown in Figure A2-1 are Type "A" (uphill) with the slopes on the first and last quarter limited to 0.8 per cent.

¹ Former aerodrome reference code in Annex 14 was based on the runway basic length, which was defined as the runway length selected for aerodrome planning purposes which is required for take-off or landing under standard atmospheric conditions for zero elevation, zero wind and zero runway slopes.

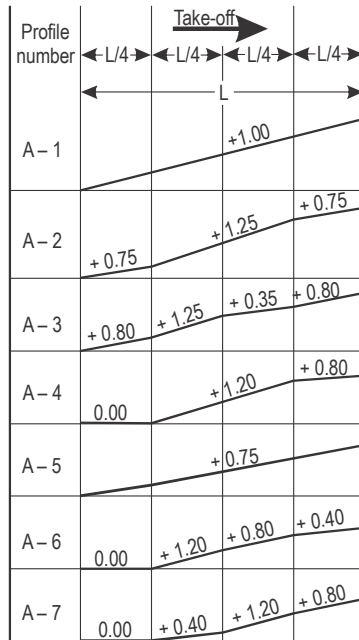

a)

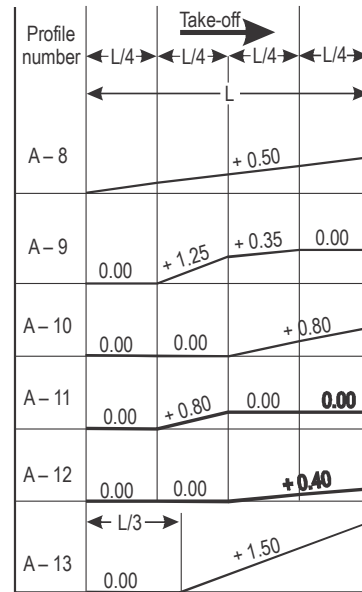

b)

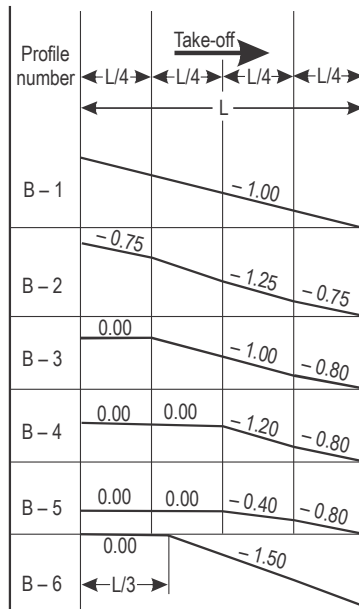

c)

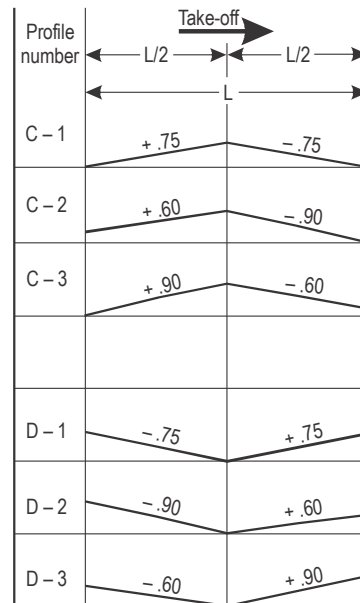

d)

Figure A2-1. Selected Study Profiles

4. DEFINING A SINGLE EQUIVALENT SLOPE

A number of single slope indices for defining non-uniform profiles were chosen for comparison as means of describing a variable slope by a single equivalent slope. Four indices, defined as follows, were compared:

Index No. 1 Average slope, defined as the difference in elevation between the end points of the runway divided by the length of the runway (referred to as Runway Slope Index No. 1).

Index No. 2 The United States definition of effective gradient which is the distance between the lowest and highest point on the runway divided by the length of the runway (referred to as Runway Slope Index No. 2).

Index No. 3 Effective gradient for take-off, which divides the runway into four equal segments; determines the average slope in each segment; and the slopes as follows:

$$G_e = \frac{G_1 + G_2 + 2G_3 + 4G_4}{8} \quad (\text{referred to as Runway Slope Index No. 3})$$

where G is the average segment slope.

Index No. 4 Modification of Index No. 3 as follows:

$$G_e = \frac{G_1 + 1\frac{1}{3}(G_2) + 2\frac{1}{3}(G_3) + 3\frac{1}{3}(G_4)}{8} \quad (\text{referred to as Runway Slope Index No. 4})$$

It will be noted that Indices No. 3 and No. 4 reflect the greater influence of the runway slope at the high speed portion of the take-off run.

5. CONCLUSIONS

From the study it was concluded that:

- a) based on the data available, Indices No. 1 and No. 4 describe the influence of variable runway profiles better than Indices No. 2 and No. 3;
- b) for jet aircraft, Slope Index No. 1 is adequate for describing the effect of a variable slope on runway length. For piston-engined aircraft, Slope Index No. 4 is superior to the other indices tested;
- c) the magnitude of the correction is larger for piston-engined aircraft than for jet aircraft;
- d) the magnitude of the positive correction is greater than that of the negative corrections;
- e) the effect of an elevation difference of 300 m on runway correction was found to be negligible for all aircraft included in this study; and
- f) the study suggests that refinement of the methods used in 4.1 for calculating runway slope index is not warranted for the purpose of planning runway lengths.

6. RECOMMENDATIONS

6.1 If the runway length is governed by jet aircraft, it is recommended that Slope Index No. 1 be used, with the following correction applied to the required level runway length:

$$\text{Per cent runway correction} = 1.0 + 6.0 (\text{Slope Index No. 1})$$

where the slope index can be either a positive or a negative value. This would apply only to runways that are not level.

6.2 If the runway length is governed by piston-engined aircraft, it is recommended that Slope Index No. 4 be used, with the following corrections applied to the required level runway length:

For positive index values:

$$\text{Per cent runway correction} = 12.0 (\text{Slope Index No. 4})$$

For negative index values:

$$\text{Per cent runway correction} = 8.0 (\text{Slope Index No. 4})$$

6.3 If it is desired to use a single index for all aircraft types, it is recommended that Slope Index No. 4 be used and the following corrections applied:

For positive index values:

$$\text{Per cent runway correction (jet aircraft)} = 7.0 (\text{Slope Index No. 4})$$

$$\text{Per cent runway correction (piston aircraft)} = 12.0 (\text{Slope Index No. 4})$$

For negative index values:

$$\text{Per cent runway correction (jet aircraft)} = 4.0 (\text{Slope Index No. 4})$$

$$\text{Per cent runway correction (piston aircraft)} = 8.0 (\text{Slope Index No. 4})$$

Appendix 3

AEROPLANE PERFORMANCE CURVES AND TABLES FOR RUNWAY PLANNING PURPOSES

1. INTRODUCTION

1.1 Runway length criteria for general airport planning information have been developed in the form of aeroplane performance curves and tables on landing and take-off operations. An aeroplane performance landing curve is a chart for a particular aeroplane, based on its performance capabilities, which relates aeroplane landing mass and aerodrome elevation to the runway length required for landing. An aeroplane performance take-off curve is a chart for a particular aeroplane based on its performance capabilities, which relates aeroplane take-off mass or flight distance, aerodrome elevation and temperature to the runway length required for take-off.

1.2 An aeroplane performance table serves a purpose similar to the aeroplane performance curve. Whereas in the performance curves the relationship between the operational factors and runway length required is expressed in a graphical form, in the performance tables the relationship is expressed in tabular form.

1.3 Advisory Circular AC 150/5325-4B, *Runway Length Requirements for Airport Design* produced by the Federal Aviation Administration (FAA), United States, contains planning data for landing and take-off requirements of commonly used aeroplanes. The data are presented in the form of performance curves and tables. The circular includes examples with instructions on the use of the performance curves and tables, and a discussion of the factors considered in their development. The relationship between elevation, temperature, aeroplane mass and runway length presented in the performance curves and tables is based on flight test and operational data except for those cases where preliminary performance data, based on estimated operational data, have been developed.

1.4 Aeroplane performance curves for runway planning purposes can also be found in the aircraft characteristics documents for airport planners. These documents contain basic planning information on aircraft and are made available in a standardized format by aircraft manufacturers with the assistance of airlines and aerodrome authorities. The documents include data for those existing aeroplane types which are expected to constitute the bulk of the international fleet for the next few years.

2. PARAMETERS TAKEN INTO ACCOUNT IN THE PERFORMANCE CURVES AND TABLES

General

2.1 Besides the basic design features including aerodynamic and powerplant characteristics of the aeroplanes, the factors which affect the runway length requirements include: aeroplane configuration, aeroplane mass, atmosphere (ambient air pressure, temperature and relative humidity), runway slope, runway state, and wind. However in the construction of take-off and landing performance curves and tables, it is a usual practice to relate these factors to a standard relative humidity and zero runway slope.

Aeroplane types

2.2 The differences in the certification and operational requirements between types of present day aeroplanes demand individual consideration of the runway length required by each aeroplane at each aerodrome. Both the landing and take-off runway length requirements must be considered in order to determine which is greater.

Aeroplane configuration

2.3 Aeroplane configuration refers to the position of the various elements of the aeroplane affecting its aerodynamic characteristics. The following elements affect aeroplane performance:

- a) *Wing flaps and other lift-increasing devices.* In the construction of the FAA aeroplane performance curves and tables (relating to the take-off and landing distance) the position of the wing flaps (and of other lift-increasing devices as slats, droop leading edges, etc., if applicable) normally used for the combination of aeroplane mass, temperature and altitude has been chosen.
- b) *Air brakes and other drag-increasing devices.* In the construction of the FAA aeroplane performance landing curves and tables the position of the air brakes and the other drag-increasing devices, if applicable, normally used for the combination of aeroplane mass and altitude has been chosen.
- c) *Other systems.* The use of an anti-icing system and windshield wipers, the position of cowling flaps, etc., also affect runway length required. In developing the FAA aeroplane performance curves and tables these systems have been assumed to be in the position requiring the shorter runway.

Atmosphere

2.4 The atmosphere plays an important part in the runway length required. The atmosphere is a related combination of pressure, temperature and density.

- a) *Altitude.* Generally, as height above sea level increases, the air pressure and density become less. The consequence of these factors upon aeroplane operations is a reduction of lift for a given true airspeed, a reduction of power and a reduction of propeller efficiency, if applicable. The combined result of these reductions is that it takes longer to attain the forward speed necessary to produce the required lift, thus the runway length required for take-off for a given aeroplane becomes progressively longer as it is operated from aerodromes at higher altitudes. Similarly, at higher altitudes, true landing speeds are greater, and less dense air reduces the drag available to assist in decelerating during the landing roll. In the aeroplane performance curves and tables the runway length required is given for varying pressure altitudes (defined by the ICAO Standard Atmosphere) as is also done in the aeroplane flight manuals, but the pressure altitude lines are labelled as aerodrome elevation. This substitution is warranted because of the degree of similarity between the average pressure altitude and the elevation of a location. Since the likelihood of simultaneous occurrence of both maximum pressure altitude (minimum pressure) and mean maximum temperature (aerodrome reference temperature) is very slight, the use of both maximum altitude and temperature may result in an uneconomical runway length.
- b) *Temperature.* The performance of an aeroplane depends on several factors among which temperature is important. At a given pressure, higher temperature results in lower air density and so has an adverse effect on both piston-engined and jet aeroplanes. This effect is usually greatest when taking off, especially for aeroplanes equipped with turbo-jet engines. The efficiency of a turbo-jet engine depends in part on the difference between the outside air temperature and the maximum temperature attainable in the combustion chamber. As the outside temperature increases above a certain value depending on

the altitude, engine efficiency is decreased and, therefore, the aeroplane's performance is reduced. A temperature not lower than the aerodrome reference temperature, as defined in Annex 14, Chapter 2, should be used. The effect of temperature is considerably greater on the take-off distance (and take-off run) than on the landing distance. Moreover the landing distance given in the flight manual usually is multiplied by an operational factor of the order of 1.67. Since the influence of the temperature alone on the landing distance is considerably smaller, only the influence of the ambient air pressure (with the temperatures corresponding to the Standard Atmosphere) on the landing distance is usually taken into account. However, the take-off distances (and take-off runs) are determined taking into account the influence of the ambient air temperature.

Wind

2.5 The aerodrome must be designed to accommodate aeroplane operations under most normal wind conditions. A tail wind on one runway is a head wind on a runway with a reciprocal heading. Runway lengths increase with tail wind, so when using the bi-directional runway concept (i.e. theoretically utilizing a head wind for all conditions in establishing runway length), the zero-wind condition is critical for both take-off and landing. This requires, however, a change in operational direction on the runway each time the wind changes direction and does not provide adequate length when tail wind operations are conducted because of preferential runway use. The problem is further compounded by the fact that winds up to 9.2 km/h (5 kt) are reported as "calm". The FAA landing performance curves and tables are usually based on a 9.2 km/h (5 kt) tail wind to recognize the flexibility required in aeroplane landing operations. The FAA take-off performance curves and tables, however, are developed for zero wind. The take-off performance curves in the aeroplane characteristic documents for airport planners are developed for zero wind and the landing performance curves are developed for zero wind at 15 m (50 ft) height.

Aeroplane mass

2.6 The greater an aeroplane's mass, the longer its required runway length, both for landing and for taking off. The mass of an aeroplane is made up of three major items:

- a) aircraft prepared for service (APS) mass (or operating mass empty) which usually includes:
 - 1) aircraft empty mass;
 - 2) crew mass, crew's baggage, engine oil and removable emergency equipment mass;
 - 3) unusable fuel mass;
- b) payload; and
- c) fuel load.

Items b) and c) are self-explanatory.

The total of the APS mass and payload will vary and may need to be considered on a local basis. This mass is often referred to, for operational purposes, as the "zero fuel mass" and the maximum value is given as a structural limitation in the flight manual.

2.7 In the FAA aeroplane performance tables, the runway lengths required are related directly to the operating mass of the aeroplanes. However, in the FAA aeroplane performance curves, the runway lengths required may be related to flight stage lengths. In these curves it has been assumed that aeroplanes take off with the maximum payload permissible

under the circumstances. If the take-off mass is not limited by any of the conditions enumerated in 2.11 b), the payload can be as much as the aeroplane structure permits, i.e. the maximum zero fuel mass minus the APS; on the other hand, if the take-off mass is limited by any of the conditions, the payload must be reduced. These curves make allowance for this.

2.8 Annex 6, Part I, Chapter 4, specifies the amount of fuel to be carried by aeroplanes for two cases:

- a) when a destination alternate aerodrome is required; and
- b) when a destination alternate aerodrome is not required.

In the FAA aeroplane performance, only case b) has been taken into account. According to the Annex, in this case a flight shall not be commenced unless, taking into account both the meteorological conditions and delays that are expected in flight, the aeroplane carries sufficient fuel and oil to ensure that it can safely complete the flight. In addition, a reserve shall be carried to provide for contingencies and to enable the aircraft to reach an alternate aerodrome. In order to comply with this, the fuel shall be at least the amount sufficient to allow the aeroplane:

- a) in the case of *propeller-driven aeroplanes*, to fly to the aerodrome to which the flight is planned, thence to the most critical (in terms of fuel consumption) alternate aerodrome specified in the operational flight plan and thereafter for a period of 45 minutes;
- b) in the case of *aeroplanes equipped with turbo-jet engines*, to fly to and execute an approach and a missed approach at the aerodrome to which the flight is planned and thereafter:
 - 1) to fly to the alternate aerodrome specified in the flight plan, and then
 - 2) to fly for 30 minutes at holding speed at 450 m (1 500 ft) above the alternate aerodrome under standard temperature conditions, and approach and land, and
 - 3) to have an additional amount of fuel sufficient to provide for the increased consumption on the occurrence of any of the potential contingencies listed below and specified by the operator to the satisfaction of the State of the Operator:
 - i) meteorological conditions forecast;
 - ii) expected air traffic control routings and traffic delays;
 - iii) one instrument approach at the destination aerodrome, including a missed approach;
 - iv) the procedures prescribed in the operations manual for loss of pressurization, or failure of one power unit while en route; and
 - v) any other conditions that may delay the landing of the aeroplane or increase fuel and/or oil consumption.

Annex 6 also specifies the amount of fuel in a case where the aeroplane flies directly to the alternate aerodrome without overflying the aerodrome to which the flight is planned. This case is not the primary concern to aerodrome engineers and was disregarded in the FAA aeroplane performance curves.

2.9 In order to assess the required amount of fuel, the average representative fuel consumption rate has been statistically obtained in the FAA aeroplane performance curves for each type of aeroplane by averaging the amount of fuel consumed for a unit distance and for a unit flight time. The use of this average is justified for aerodrome design purposes

as the rate is almost constant for each aeroplane type, and there has been no significant divergency for a wide range of different stage distances. The distance scale for the take-off performance curves has been scaled to this average representative fuel consumption rate.

2.10 In the FAA aeroplane performance curves the distance from the aerodrome of destination to an alternate aerodrome has uniformly been assumed to be a 30-minute flight. In addition, the amount of fuel required for a 45-minute flight at an average altitude has been taken into account. The amount of fuel required for a turbo-jet aeroplane to fly for 45 minutes at the average altitude at the average speed is considered to be almost equivalent to that required for a 30-minute flight at holding speed at 450 m (1 500 ft) above an aerodrome. Further, the average representative fuel consumption rate has been obtained by dividing the actual fuel consumption by the distance flown and by the flight time on a block-to-block basis and it therefore includes, on an average basis, the factors enumerated in 2.8 3) b).

2.11 Aeroplane landing and take-off masses calculated should not be greater than the following limits:

- a) *Landing mass.* Aeroplanes land at a mass up to the maximum landing mass which falls into one of two types:
 - 1) *Structural limitation.* Maximum landing mass based on structural limitation is constant regardless of the operational parameters such as temperature and wind.
 - 2) *Climb performance.* Maximum landing mass based on a climb limitation varies with pressure-altitude and temperature. An increase in pressure-altitude and/or temperature decreases the maximum allowable landing mass.
- b) *Take-off mass.* Aeroplanes take off at a mass up to maximum take-off mass which falls into one of five types:
 - 1) *Structural limitations.* Maximum take-off mass based on climb structural limitations is constant regardless of pressure-altitude, temperature, wind and runway slope.
 - 2) *Climb performance.* Maximum take-off mass based on climb limitations varies with pressure-altitude and aerodrome temperature. An increase in pressure-altitude and/or temperature decreases allowable take-off mass.
 - 3) *Tire speed.* Maximum take-off mass based on tire speed limitations varies with pressure-altitude, temperature and tail wind. An increase in any of these factors, singly or in combination, decreases maximum allowable take-off mass.
 - 4) *Maximum landing mass.* Take-off mass less the fuel mass consumed to fly to the aerodrome to which the flight is planned should not exceed the maximum landing mass at that aerodrome to ensure safe landing after a normal flight. (See Annex 6, Part I, 5.2.)
 - 5) *Obstacle clearance.* Maximum take-off mass based on obstacle clearance limitation is dependent on the location and height of obstacles in the vicinity of the runway end. In the development of the FAA aeroplane performance curves, it has been assumed that there are no obstacles that may adversely affect aeroplane operations.

Runway surface state

2.12 A snow-, slush-, ice- or water-covered runway surface will increase the length of runway required for take-off and for landing. In the FAA aeroplane performance curves a dry hard runway surface has been assumed unless

otherwise stated; in the tables, however, the landing lengths assume a wet runway and no further correction to the length is necessary for a wet runway. The landing performance curves in the aeroplane characteristics documents for airport planners are developed for dry and wet runway surface conditions.

Appendix 4

RUNWAY TURN PADS

1. INTRODUCTION

Annex 14, Volume I requires that aircraft turn pads be provided on runways at airports where a taxiway system, capable of facilitating faster clearance of landing aircraft from the runway, is not provided. A runway turn pad is defined as an area on a land aerodrome adjacent to a runway for the purpose of completing a 180-degree turn on a runway where no taxiway exists. The additional pavement of the turn pad is intended to facilitate the safe and easy turn-around of aircraft while enhancing airport capacity at such airports. With careful planning, additional taxiway components can be added to the system in stages to keep pace with traffic growth. See Figure A4-1.

2. LOCATION

Runway turn pads should be located on either side of the runway, adjoining the pavement at both ends of the runway. Where deemed necessary, runway turn pads may also be located along the runway at intermediate locations.

3. DESIGN CONSIDERATIONS

3.1 To facilitate the entry of aircraft onto the turn pad from the runway, the intersection angle of the turn pad with the runway should not exceed 30 degrees. The total width of the turn pad and runway should be such that the nose wheel steering angle of the aircraft for which the turn pad is intended will not exceed 45 degrees. The design of the runway turn pad should be such that when the cockpit of an aeroplane is over the turn pad marking, the wheel-to-pavement edge clearance distance should not be less than that specified in Annex 14, Volume I. An example of the pavement required for a Code letter "A" aircraft to complete a 180-degree turn on a 30 m wide runway is found in Figure A4-2. Examples of runway turn pad designs can be found in Figures A4-3 to A4-7.

3.2 Where severe weather conditions (rain and/or snow) and resultant lowering of surface friction characteristics prevail, a larger wheel-to-pavement edge clearance of 7 m should be provided for codes E and F aeroplanes. Nevertheless, the surface of a runway turn pad should be so constructed as to provide good friction characteristics for aeroplanes using the facility when the surface is wet, and it should be sloped to prevent the accumulation of water and promote drainage. Suitable longitudinal and transverse slopes contiguous with the associated runway slopes and not exceeding 1 per cent should be provided.

3.3 The pavement strength of the turn pad should be at least equal to that of the runway served by the turn pad, and it should be able to withstand the higher stresses put on the pavement by a slow moving aeroplane making hard turns. In the case of flexible pavements, the surface would need to be capable of withstanding the horizontal shear forces exerted by the main landing gear tires during turning manoeuvres.

4. SHOULDERS

4.1 Runway turn pads should be provided with shoulders that are wide enough to prevent jet blast surface erosion from the turning aeroplane and foreign object ingestion damage to the aeroplane engines. As a minimum, the width of the shoulders would need to cover the outer engine of the most demanding aeroplane and thus may be wider than the associated runway shoulders.

4.2 Runway turn pad shoulders should be capable of withstanding the occasional passage of the aeroplane it is designed to serve without inducing structural damage to the aeroplane and to the supporting ground vehicles that may operate on the shoulder.

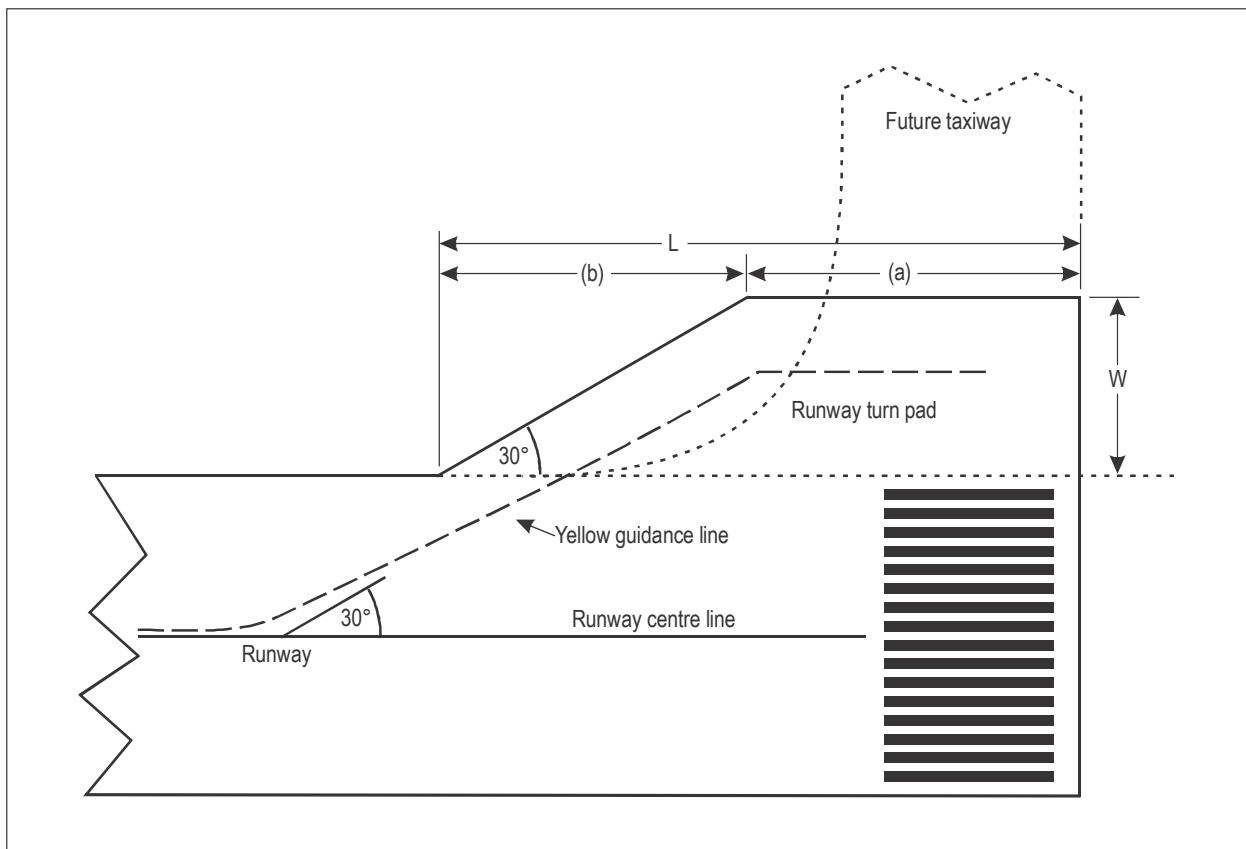

Figure A4-1. Runway turn pad. Typical design

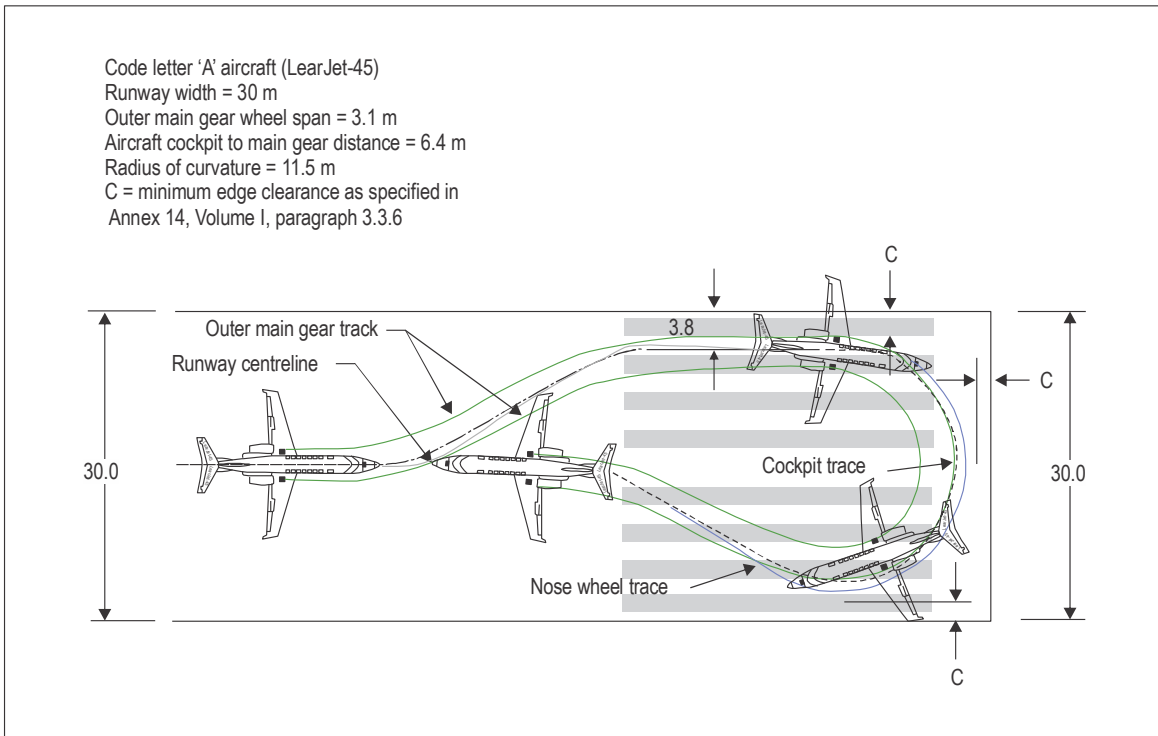

Figure A4-2. Pavement required to complete a 180-degree turn —Code letter “A” aircraft

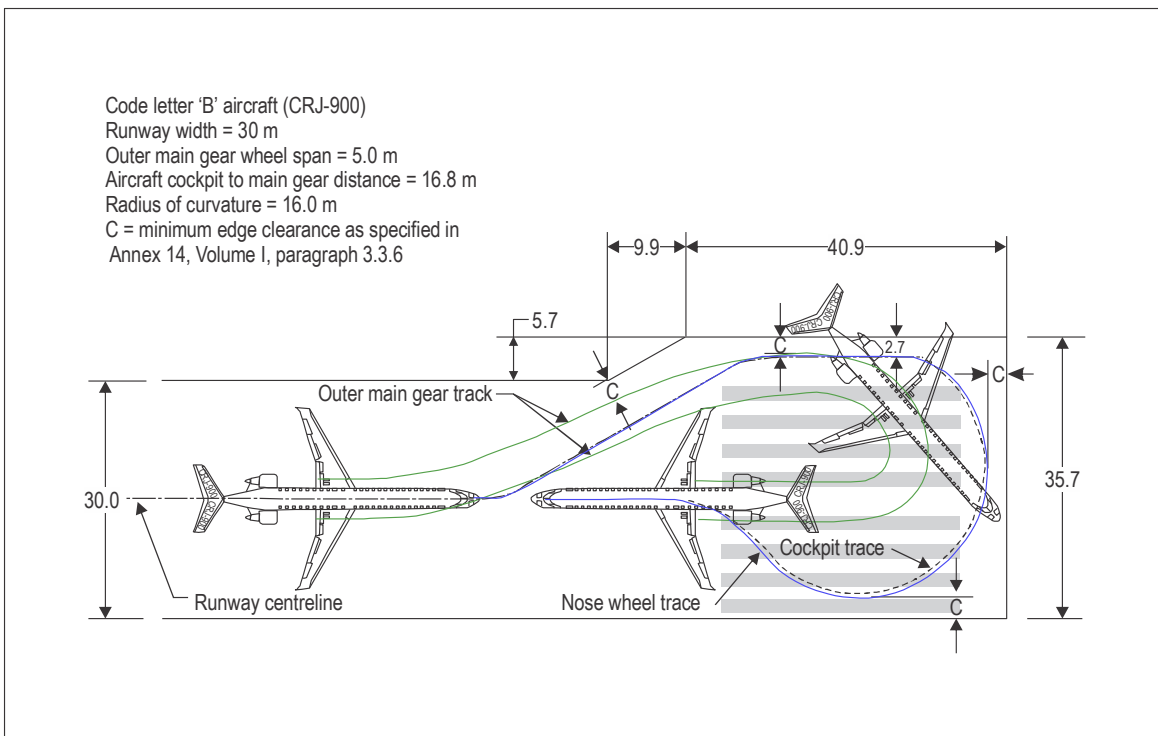

Figure A4-3. Turn pad design for a Code letter “B” aircraft

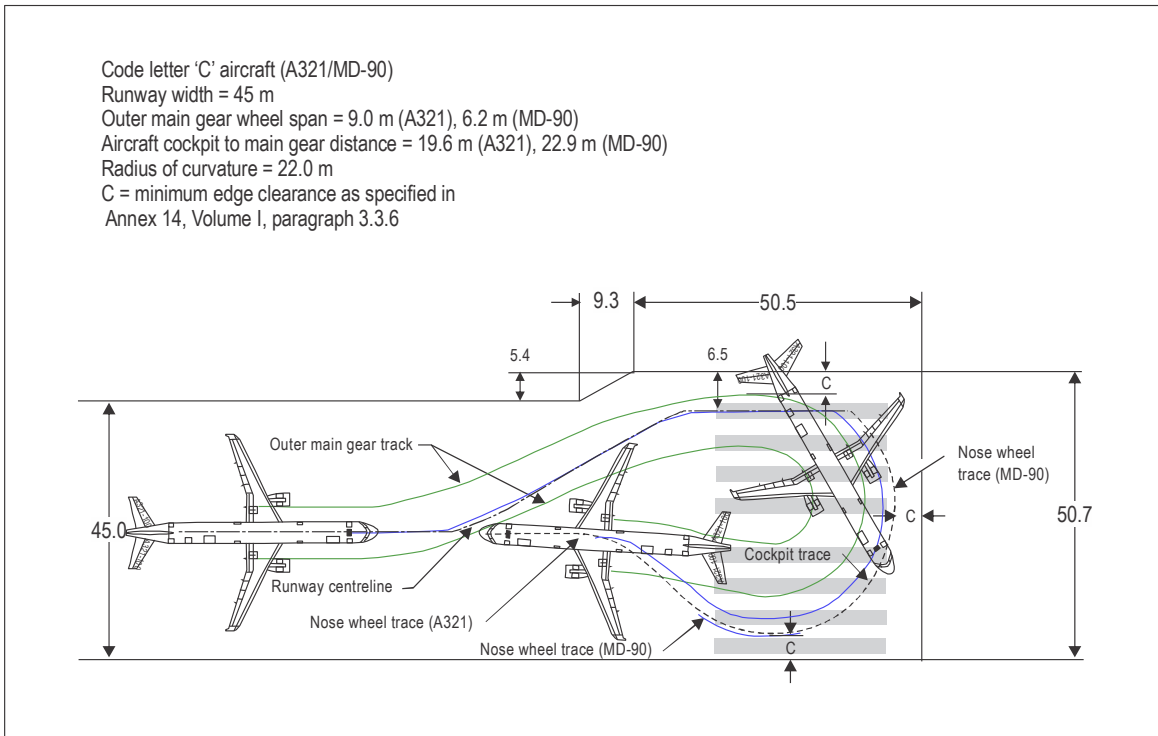

Figure A4-4. Turn pad design for a Code letter “C” aircraft

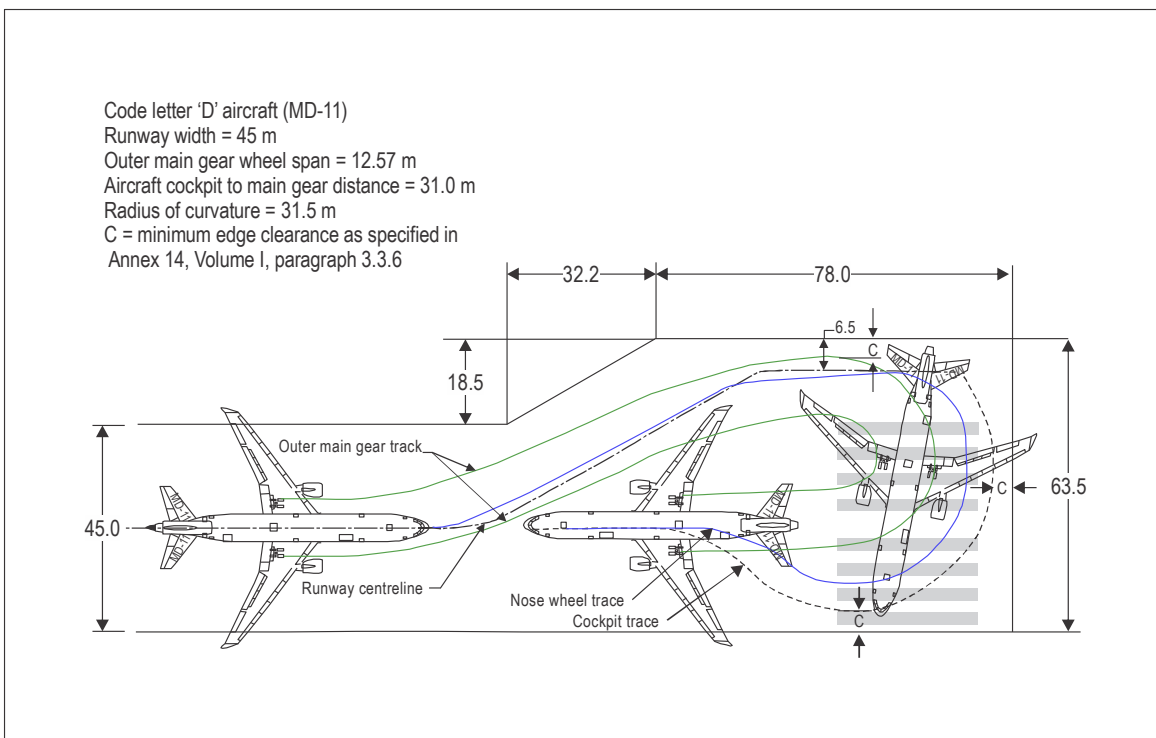

Figure A4-5. Turn pad design for a Code letter “D” aircraft (MD-11)

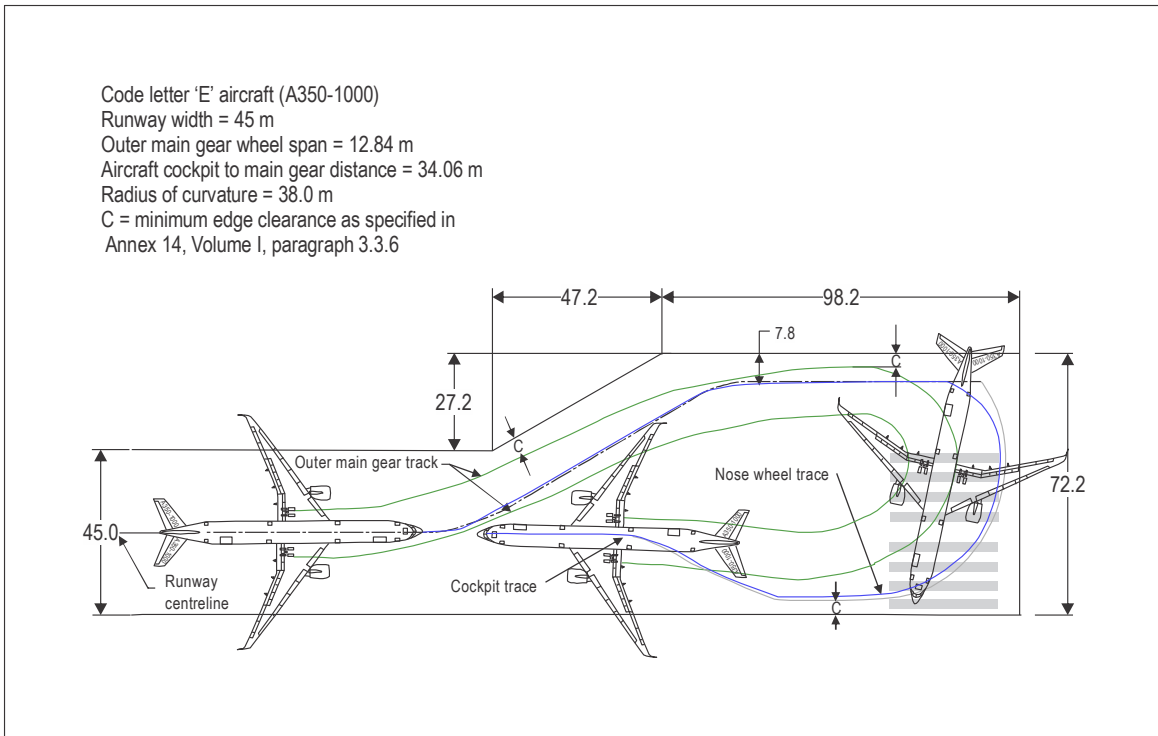

Figure A4-6. Turn pad design for a Code letter “E” aircraft (A350-1000)

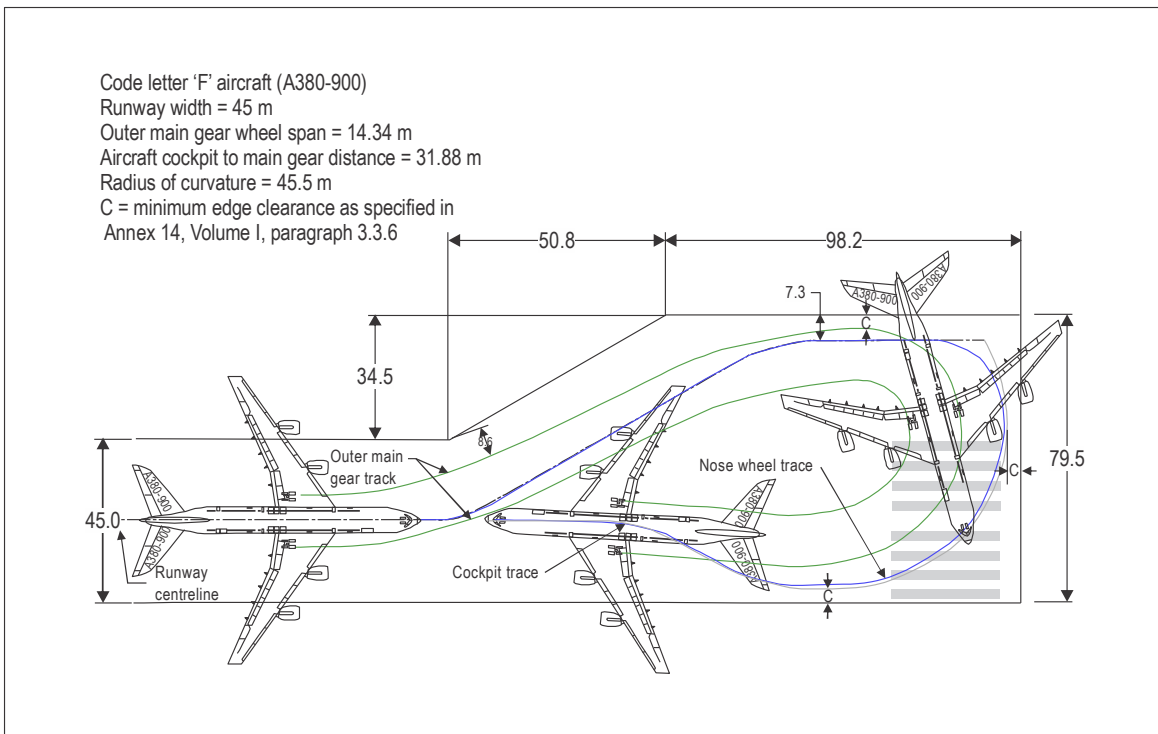

Figure A4-7. Turn pad design for a Code letter “F” aircraft

Appendix 5

AIRCRAFT ARRESTING SYSTEMS

Note.—This appendix includes performance and compatibility requirements applicable for aircraft arresting systems such as EMAS that are known to be widely used for commercial aeroplanes. Although the guidance below has been drafted according to this subtype, these performance and compatibility requirements may also be applied to other similar subtypes of arresting systems with appropriate adjustments.

1. INTRODUCTION

1.1 An Aircraft Arresting System (AAS) is a system designed to decelerate an aeroplane overrunning the runway. In accordance with Annex 14, Volume I, if an arresting system is installed, the length of the standard or recommended RESA may be reduced, based on the design specification of the system, subject to acceptance by the State. AASs provide predictable and effective performance in arresting aircraft overruns, independent of the weather.

1.2 *Engineered Materials Arresting System (EMAS)* consists of high energy absorbing materials of specific strength, which will reliably and predictably crush under the weight of an aircraft. The materials are tailored to specific mechanical properties and are referred to as Engineered Materials. The Engineered Materials will be crushed under the landing gears of the aeroplane when it engages the EMAS. The crushing is an irreversible or partly irreversible process and the arresting performance of the system is proportional to the amount of energy that is dissipated.

1.3 These requirements provide guidance that may be considered as an initial draft for national rules, or to be used directly as applicable provisions and are complementary to national requirements regarding industry, environment or emergency plans.

1.4 Suggested procedures to be followed prior to the installation of EMAS normally include two steps:

- a) firstly, manufacturers need an EMAS type acceptance/approval from the State, demonstrating compliance to general requirements; and
- b) secondly, once the EMAS type is accepted, aerodrome operators can make a proposal by providing particular details of the EMAS to be installed and will need prior approval given by the State.

Note.— The oversight carried out by States for EMAS type acceptance/approval may include a review of testing conducted previously, a detailed programme of evaluations and tests, or be based on the acceptance of certificates of compliance. As it is understood that the initial acceptance/approval by each State may be a time- and resource-consuming effort, it is suggested to take into account the compliance demonstrations used in other States before requesting new testing programmes.

1.5 Research programmes, as well as the evaluation of actual aeroplane overruns into an EMAS installation, have demonstrated that these systems are effective in arresting aeroplane overruns. The documents listed below provide guidance on the requirements and evaluation process used by the following States for EMAS systems:

China

- MH/T 5111 — 2015 *Engineered Materials Arresting System (EMAS)*. (Issued by Civil Aviation Administration of China).

France

- Provisions concerning arresting systems installed in runway-end safety areas (Direction générale de l'aviation civile (DGAC)).

Japan

- *Design Standards for Airport Civil Engineering Facilities* (Ministry of Land, Infrastructure, Transport & Tourism Civil Aviation Bureau).
- *Airport Civil Engineering Facility Structure Design Manual* (Ministry of Land, Infrastructure, Transport & Tourism Civil Aviation Bureau).

United States

- FAA Advisory Circular 150/5300-13: Airport Design;
- FAA Advisory Circular 150/5220-22B: Engineered Materials Arresting Systems (EMAS) for Aircraft Overruns;
- FAA Order 5200.8: Runway Safety Area Program;
- FAA Order 5200.9: Financial Feasibility and Equivalency of Runway Safety Area Improvements and Engineered Material Arresting Systems

2. CONCEPT AND OPERATION

2.1 The EMAS is designed to slow down aircraft in the event of an overrun by exerting predictable forces on the landing gear. The forces exerted onto the gears are not designed to be excessive so as to avoid injuries to passengers or crew members, nor cause major structural damage to the aircraft.

2.2 The EMAS is a passive system which requires no external means to initiate/trigger the operation of arresting an aircraft, nor does it require any special actions or procedures of the flight crew.

Note.— Although the EMAS is a passive system, a basic knowledge of the systems by the crew is considered advantageous to prevent undesired evasive manoeuvres that could cause the aircraft to avoid entering the bed or system. EMAS is designed to be entered preferably straight ahead with the unrestricted use of wheel brakes and/or thrust reversers.

2.3 The EMAS is not intended to meet the definition of a stopway, and its availability is not to be used for flight planning purposes.

3. LOCATION AND DIMENSIONS

3.1 An EMAS is located beyond the end of the runway (or stopway, if provided) at enough setback distance in order to avoid damage due to jet blast.

Note.— The setback is defined as the distance between runway end or stopway and the beginning of the EMAS. The minimum setback distance required for jet blast protection may differ depending on the manufacturer and the operational conditions.

3.2 The calculation of the setback distance balances the risk objectives of:

- a) providing enough area for arresting purposes;
- b) providing enough separation to protect the bed from jet blast;
- c) providing separation from the threshold to reduce the probability of undershoot in the EMAS; and
- d) decreasing the probability of aircraft overruns passing by one side of the EMAS due to lateral dispersion.

3.3 The relevance of each risk objective, taking into account the operating conditions of the associated runway including usage of the runway, types of approach, weather conditions, fleet mix, incidents and accidents, and any other runway safety issues can be determined by the conduct of a safety assessment (see Doc 9981, *Procedures for Air Navigation Services (PANS) — Aerodromes*, Chapter 3 for procedures on the conduct of a safety assessment).

3.4 In order to reduce the probability of an aircraft undershooting in an EMAS, it is recommended to provide a minimum setback distance of at least 60 m from the threshold or the runway end. However, this separation may be reduced if, after an aeronautical study, it is determined that it is the best alternative for both overrun and undershoot protection.

3.5 The EMAS functional length is designed based on the operating conditions of the associated runway with its centre line coincidental with the extended centre line of the runway.

3.6 The EMAS functional width may not be less than the runway width. Where possible, this width is provided throughout the whole length of the bed.

Note.— Steps and/or slopes normally provided at its end and at both sides of a EMAS bed are not considered functional for arresting purposes.

4. DESIGN AND ARRESTING PERFORMANCE

Note.— Considering the surface of a RESA may vary depending on the type of soil or pavement, resulting in diversity in the decelerating performance and characteristics of overrunning aircraft, it is not easy to establish a correlation between the performances of a RESA and an EMAS, the latter of which is designed to provide the optimal arresting response achievable with the distances available.

4.1 *Exit speed* is defined as the speed of the nose gear of the aeroplane as it passes the physical end of the runway or stopway, if provided.

4.2 *Critical aircraft* is defined as that aircraft regularly using the associated runway that imposes the greatest demand on the EMAS.

4.3 *Design aircraft list* refers to the combination of aircraft types which are/will be operating regularly on the runway.

Note.— The critical aircraft is usually, but not always, the heaviest/largest aircraft that regularly uses the runway. EMAS performance is dependent not only on aircraft weight, but also on the landing gear configuration, tire

pressure and the center of gravity. In general, the operational maximum take-off weight (operational MTOW) is used for the critical aircraft. However, there may be instances where less than the MTOW will require a longer arrester bed. All parameters are to be considered in optimizing the design. To the extent practicable, the design is required to consider both the aircraft that imposes the greatest demand upon the EMAS and the range of aircraft expected to operate regularly on the runway. In some instances, a combination of design aircraft may be preferable in optimizing the EMAS than a single critical aircraft. Other factors unique to a particular aerodrome, such as available RESA and air cargo operations, are also considered in the final design. The aerodrome operator, EMAS manufacturer, and the State must consult regarding the selection of the design aircraft that will optimize the EMAS for a specific runway.

4.4 In addition to validating the EMAS design that is able to predict the performance of the system, the design method is further validated through laboratory or preferably, in situ tests.

Note.— EMAS testing is based either on passage of an actual aircraft or a single wheel bearing an equivalent load through a test bed. The design considers multiple aircraft parameters, including but not limited to allowable aircraft gear loads, gear configuration, tire contact pressure, weight, centre of gravity and speed.

4.5 To the maximum extent possible, EMAS is designed to decelerate the designated aircraft at an exit speed of 70 knots at both MTOW and 80 per cent maximum landing weight (MLW) without imposing loads that exceed the design limits of the aircraft, which may cause major structural damage to the aircraft or impose excessive forces on its occupants. Where there is insufficient distance available for achieving this objective, the EMAS is designed to achieve the maximum arresting performance of the critical aeroplane within the available distance.

Note.— The 70 knots requirement is based on the state-of-the art design for EMAS, and the analysis of overrun data. It is not possible to establish an equivalence between the performance of RESA and EMAS, as one is based on stopping distance and the other on speed. Therefore, some States accept a 70 knots performance as equivalent (or better due to its predictability) to a recommended RESA.

There are records of aeroplane overruns with exit speeds of more than 70 knots, as there are records of overruns that travel more than 300 metres. It is to be emphasized that if the 70 knots requirement is achieved for the critical aeroplane, the arresting performance will normally be better for the rest of the aeroplanes in the design aircraft list.

4.6 The design method for EMAS excludes the use of reverse thrust of the aeroplane, using a 0.25 braking friction coefficient for the runway and length of pavement prior to the arrester bed (also known as the setback). The design method for the EMAS assumes no braking friction coefficient (0.00) within the EMAS arrester bed itself, unless the EMAS manufacturer can provide documentation of field or laboratory testing which demonstrates the minimum actual braking friction coefficient that can be achieved as an aeroplane passes through the arrester bed material. The designed arresting bed distance is the theoretical calculated distance with margin which could cover the calculation error.

5. ADJACENT AREAS

On both sides of the EMAS, the requirements for RESA according to the relevant provisions in Annex 14, Volume I, Chapter 3, Section 3.5 are applicable. Service roads, set up at both sides and at the end of the EMAS, are intended for maintenance and emergency access. Service roads are provided with adequate width to allow ingress and egress of Rescue and fire fighting service (RFFS) vehicles, graded to avoid water accumulation and are capable of supporting the passage of fully loaded RFFS vehicles.

6. UNDERSHOOTS

The EMAS is designed so as not to increase the potential for damage in case of an undershoot and so it does not cause more control problems for or damage to aircraft for undershoots which touch down on it compared with a RESA.

Notes.— It is commonly accepted that compliance with this requirement is difficult to justify, particularly concerning the numerous variety of undershoot scenarios. Consequently, the compliance with this requirement could be justified through experience of real cases of undershoot in EMAS, flight simulator tests, other type of studies or a combination thereof.

The objectives of reducing the risk of damage to an aeroplane undershooting or overrunning the runway are both included in the definition of a RESA. However, different studies⁺ developed in the United States and in the European Union with worldwide data show that undershoots occur normally in close proximity to the runway, and the probability of undershoot decreases when instrumental or visual vertical guidance is provided to pilots.

According to the studies, approximately 50 per cent of undershoots occur in the first 60 metres before the runway threshold, and the ratio of undershoots/overruns is reported to be 1:4. This information needs to be taken into account in the safety assessment developed, to find the best solution for enhancing runway safety.

EMAS is not intended to reduce the risk of damage to an aeroplane undershooting the runway. However, the presence of an AAS does not increase the potential for damage in case of undershoot more than the risk associated with an undershoot in a RESA.

⁺ ACRP Report 50. Improved Models for Risk Assessment of Runway Safety Areas
EASA_REP_RESEA_2011_12. Study on models and methodology for safety assessment of Runway End Safety Areas (RESA)

7. OTHER CONSIDERATIONS

7.1 Although the EMAS is not regarded as an obstacle on the runway strip or in the RESA for clearing and grading requirements, it is required to be frangible, and to be mounted as low as possible with ramps provided to avoid vertical surface, wherever feasible.

7.2 The arrester bed is prepared in such a manner so as not to be damaged by jet blast or projected debris during normal aircraft operations.

Note.— EMAS is composed of material with the necessary protection to achieve this requirement during its service life.

7.3 The mechanical property of the arrester bed is required to be adequate enough to avoid damage resulting from personnel walking on it for routine maintenance. However, the bed is not intended to support vehicular traffic for maintenance or normal operating purposes.

7.4 The presence of the arrester bed will not hinder the movement of the Rescue and fire fighting service (RFFS) vehicles during an emergency. Adequate slopes or steps are to be provided to allow the entrance of these vehicles from the front and sides.

Note.— It is envisaged that the arrester bed may be damaged during vehicle accesses.

7.5 The arrester bed may not impede crew and passenger evacuation. Adequate slopes or steps may be provided around the perimeter.

7.6 The bed uses materials that do not generate or worsen fire hazards for incoming aircraft, and that are non-sparking, non-flammable, do not promote combustion, and/or emit toxic or malodorous fumes in a fire environment after installation.

7.7 The follow are additional requirements of an EMAS system:

- a) will not impede disabled aircraft removal;
- b) will not cause visual or electromagnetic interference with any air navigation aids;
- c) compatible with the installation of approach lighting systems;
- d) compatible with the radio altimeter operating area;
- e) does not have reflecting surfaces that could cause dazzle;
- f) does not increase wildlife hazard;
- g) the bed, including its surrounding areas, is designed to prevent water from accumulating; and
- h) the bed, including its surroundings areas, is designed to allow ice and snow removal.

Note.— Precaution needs to be taken during snow and ice removal to prevent damage to the EMAS bed.

7.8 The EMAS is required to be compatible with meteorological conditions and the aerodrome environment including water, temperature, ice, snow, hail, salt, UV radiation, de-icing and anti-icing products, aircraft fuels, hydraulic fluids and lubricating oils, paint and herbicides. These factors need to be taken into account for estimating the service life of the system.

8. MAINTENANCE

8.1 An EMAS maintenance programme is required to be established, including preventive and corrective actions where appropriate, in order to preserve the system in adequate service condition.

8.2 The maintenance programme is provided before the installation of the EMAS and, in some cases, may require prior approval or acceptance by the State. It includes appropriate records to verify that maintenance and all required inspections have been performed.

Note.— Preventive maintenance of the EMAS normally include visual and waterproof (moisture content tests) inspections. The frequency and the type of the preventive actions may differ depending on the manufacturer and the type of system.

8.3 Maintenance personnel are required to have received adequate training to perform their duties.

Note.— Maintenance personnel may be part of the aerodrome operator staff or could be subcontracted to the EMAS manufacturer or other third parties. It is essential that the maintenance personnel are fully conversant with the maintenance programme activities to preserve the system functionality.

8.4 The maintenance programme includes tests to periodically assess the service level of the system and to schedule repair or replacement actions before the end of the service life is reached.

8.5 The EMAS is designed for repair to a usable condition (conforming to the original specifications) after an overrun or other type of physical damage. The maintenance programme includes procedures and agreements for reparation including materials in stock, materials production and supply, reparation methodologies and quality control in order to maintain the level required of the system. The repair period needs to be reasonably short in order to meet the operational and safety requirements of the aerodrome.

— END —

ISBN 978-92-9265-232-6



9

789292

652326