



Bundesamt für Zivilluftfahrt (BAZL)
Office fédéral de l'aviation civile (OFAC)
Ufficio federale dell'aviazione civile (UFAF)
Federal Office for Civil Aviation (FOCA)

3003 Bern/Berne/Berna

**Lufttüchtigkeitsanweisung
Consigne de navigabilité
Prescrizione di aeronavigabilità
Airworthiness directive**

HB 91-147

Inkraftsetzung
Date en vigueur
Entrata in vigore
Effective Date

14.5.1991

Betroffene Muster – Types concernés – Applicabilità – Models affected

FFA Flugzeugwerke Altenrhein AG, models AS202/15, /15-1, /18, /18-1, /18-2, /18-3,
serial numbers (S/N) 001 ~~–~~ 223

Anlass/Massnahmen – Objet/Mesures – Oggetto/Provvedimenti – Subject/Action

Vertical stabilizer - Cracks in rib 1 of the joint angle attachment of vertical
stabilizer - Reinforcement of rib with bracket and filler plate

Fristen – Délais – Scadenza – Compliance

In accordance with Service Bulletin; the effective date on this page is applicable

Herkunft – Provenance – Provenienza – Origin

FFA Flugzeugwerke

Bezugnahme – Référence – Riferimento – Reference

FFA Service Bulletin AS202 Bravo No. 42

Bemerkungen – Observations – Osservazioni – Remarks

"Planning Information" of SB No. 42 page 1 is attached

Rechtsmittelbelehrung siehe TM Nr.
Voies de droit voir CT no. F 80.015-10
Rimedi giuridici vedi CT no.
Right to appeal see TC no.

Seite von
Page de
Pagina di 2
Page of

SERVICE BULLETIN

Mandatory

Page 1 of 7

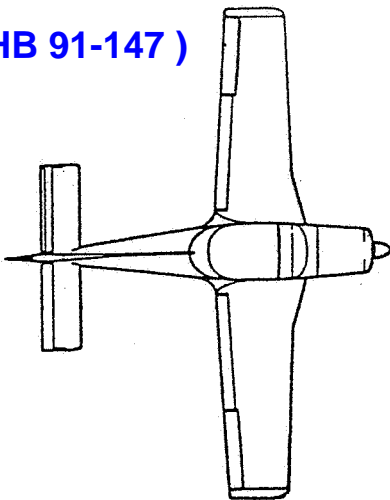

VERTICAL STABILIZER RIB 1

1. Planning Information

1.1 Effectivity

- Models: AS 202/15, AS 202/15-1
AS 202/18, AS 202/18-1
AS 202/18-2, AS 202/18-3
- Ser. Nos. S/N 001 to 223

1.2 Reason:

Cracks in Rib 1 at the joint angle attachment of vertical stabilizer

1.3 Description:

Reinforcement of Rib 1 with bracket and filler plate

1.4 Compliance:

At next 50 hours inspection

1.5 Approval:

Approved by the Swiss Federal Air Office as an Airworthiness Directive

1.6 Manpower:

Approx. 10 man-hours

1.7 Material:

Available from FFA

1.8 Tooling:

Tools for riveting required

1.9 Weight and Balance:

not affected

1.10 Electrical load data:

not affected

1.11 Reference to other publications:

IPC, chapters
55-30-01, 55-30-02, 55-50-02,
53-30-01, 27-20-02, 53-50-01,
27-20-00