

Service Bulletin No: 35-002

Ref No: 36

Modification No: EC-10-0019

ATA Chapter: 35

**OXYGEN - ON-BOARD OXYGEN-GENERATING SYSTEM (OBOGS)
DO THE MODIFICATION TO THE OBOGS WARNING CONFIGURATION****1. Planning Information****A. Effectivity**

PC-21 aircraft MSN 103 thru MSN 108.

B. Concurrent Requirements

None.

C. Reason**(1) Problem**

It has been discovered that not all BIT failures generate the correct warnings.

(2) Solution

This Service Bulletin will make sure that in future all BIT failures will be indicated correctly.

D. Description

This Service Bulletin gives the instructions and data necessary to:

- Do a modification to the OBOGS wiring in the aircraft
- Update the Line Test Equipment (LTE)
- Update the control logic in all the RIOCs to make sure the BIT fail function is not only displayed as the red OBOGS symbol on the MFD, but also shows a red OXY warning on the MFD and the DWP.

E. Compliance

Mandatory.

Required within the next 3 months after the effective date of this Service Bulletin.

F. Approval

The technical content of this Service Bulletin is approved under the authority of letter of DOA Acceptance ref. FOCA.21J.002.

PILATUS advises Operators/Owners to check with their local Airworthiness Authorities for any changes, local regulations or sanctions that may affect the embodiment of this Service Bulletin.

G. Manpower

	Total
Preparation	0.45
Do the modification to the aircraft wiring	0.45
Do the procedure to set-up the programming equipment, PR600	0.25
Do the procedure to install the LTE package	1.00
Do the procedure to install the LTE Configuration Files	1.00
Do the procedure to load the updated configuration table in the RIOC 1 thru RIOC 3	1.00
Close up	1.00
TOTAL MAN-HOURS	6.25

NOTE: Man-hours figures do not include the time required to cure sealants, paints and adhesives.

H. Weight and Balance

(1) Weight Change

Not affected.

(2) Moment Change

Not affected.

I. Electrical Load Data

Not changed.

J. Software

The software for the RIOCs is updated from 546.04.21.002 Rev. 7 to 546.04.21.002 Rev. I.

K. References

Aircraft Maintenance Manual (AMM) 21-A-06-40-00-00A-055A-A, 21-A-21-00-00-00A-012A-A, 21-A-24-40-00-00A-331A-A, 21-A-24-40-00-00A-332A-A, 21-A-25-10-00-00A-040A-A, 21-A-31-10-01-01A-040A-A, 21-A-31-10-01-08A-040A-A, 21-A-31-10-02-01A-040A-A, 21-A-31-50-01-00A-040A-A, 21-A-35-00-00-00A-012A-A, 21-A-35-00-00-00A-344A-A, 21-A-35-40-02-00A-520A-A, 21-A-35-40-02-00A-720A-A, 21-A-46-10-00-01A-750A-A, 21-A-46-10-00-02A-750A-A, 21-A-46-10-00-03A-750A-A, 21-A-46-31-04-00A-040A-A, 21-A-46-31-08-01A-040A-A, 21-A-71-00-00-00A-012A-A, 21-A-95-00-00-00A-012A-A, 21-A-95-10-00-00A-520A-A, 21-A-95-10-00-00A-720A-A

L. Publications Affected

Aircraft Wiring Manual (AWM)

M. Interchangeability of Parts

Not applicable.

2. Material Information**A. Material - Price and Availability**

No modification kit is necessary to do this Service Bulletin.

Operators who require more information should contact:

PILATUS AIRCRAFT LTD,
MANAGER, INTEGRATED LOGISTIC SUPPORT
CH 6371 STANS, Tel: +41 41 619 66 30
SWITZERLAND Fax: +41 41 610 33 51

Operators are requested to advise Pilatus Aircraft Ltd. of the Manufacturer's Serial Number (MSN), the flying hours and landings of aircraft which are allocated for this Service Bulletin using the Service Bulletin Evaluation Form.

B. Material Necessary for Each Aircraft**(1) Material to be Procured**

(a) These parts must be procured to accomplish this Service Bulletin:

NEW PART NO.	DESCRIPTION	OLD PART NO.	QTY	DISP. CODE	REMARKS
513.31.21.049	LTE CONFIGURATION FILES		1	-	Supplied on a CD by Pilatus

Disposition Codes: S - Return to Stores

(2) Operator Supplied Materials

MATERIAL NO.	DESCRIPTION	QTY	REMARKS
-	WIRE (AWG 24)	100mm	PILATUS P/N 919.79.41.301
-	CONTACT PIN	1	PILATUS P/N 971.75.17.903

C. Material Necessary for Each Spare

Not applicable.

D. Reidentified Parts

Not applicable.

E. Tooling - Cost and Availability

NEW PART NO.	DESCRIPTION	QTY	REMARKS
513.31.21.003	LINE TEST EQUIPMENT (LTE) BASIC KIT SAF	1	-
513.31.21.005	LTE SUPPORT EQUIPMENT SAF	1	-
513.35.21.003	TEST SWITCH	1	-

3. Accomplishment Instructions

WARNING: MAKE SURE THAT BOTH EJECTION SEATS HAVE THE SAFETY PINS INSTALLED IN THE SAFE FOR SERVICING LOCATIONS AND THAT THE CFS HAS THE SAFETY PIN INSTALLED IN THE SAFE POSITION BEFORE YOU GO INTO THE COCKPIT (REF. AMM, 21-A-95-00-00-00A-012A-A).

A. Preparation

- (1) Do the safety procedures for the oxygen system before you do work on the oxygen system (Ref. AMM, 21-A-35-00-00-00A-012A-A).
- (2) Remove the rear ejection seat (Ref. AMM, 21-A-95-10-00-00A-520A-A).
- (3) Remove the rear cockpit, lower-left rear-panel (Ref. AMM, 21-A-25-10-00-00A-040A-A).
- (4) Disconnect the electrical connector (P167) from the receptacle on the oxygen monitor (Ref. AMM, 21-A-35-40-02-00A-520A-A).

B. Modification (Ref. Figs. 1 thru 3)

- (1) Do the modification to the aircraft wiring:
 - (a) Disconnect and remove the wire W42A24N from between terminal 13 of the electrical connector P167 and terminal D of the electrical ground PG031 located in the rear cockpit on the left side (Ref. Hook-Up Chart, Fig. 3, Line 1).
 - (b) Install the jumper wire (Ref. Hook-Up Chart, Fig. 3, Line 2)
 - 1 Install a pin (P/N 971.75.17.903) on one end of the new wire (P/N 919.79.41.301).
 - 2 Connect the wire to terminal 13 of the electrical connector P167.
 - 3 Route the wire to terminal 19 of the electrical connector P167 and cut to length.
 - 4 Remove the pin from terminal 19 of the electrical connector P167.
 - 5 Install the pin from terminal 19 on the other end of the new wire (P/N 919.79.41.301).
 - 6 Connect the wire to terminal 19 of the electrical connector P167.
- (2) Do the procedure to install the LTE Configuration Files

Put the CD with the LTE Configuration File (P/N 513.31.21.049) in the drive D:\.

 - (a) Start the LTE Software, Administrator Section, Aircraft Tab, select one of the Aircraft to be modified (link to new software to be performed).

NOTE: After completion of the next steps, all the aircraft with the same Aircraft Configuration File will be automatically configured to the change.

- (b) In the Software Files Tab, use the browse function and create the links that follow:

“RIOCLoader Software” to
 “D:\RIOCLoader_Configuring_Package\SAFRIOCLoaderStart_C.bat”.

- (c) Select Save All.
- (d) Select the ‘Report’ button under the ‘Aircraft’ tab and do a check of the LTE Database configuration.

NOTE: All the modified aircraft should report a configuration in line with Table 1. In Table 1, the ‘X’ is used as wildcard. The rows reported by the LTE could be more than those shown in the Table or have a different order. This is dependant on the previous configuration. However, rows with the same FILE TYPE have to be identical to those in the Table 1.

TAIL NBR (AIRCRAFT NAME): XXXX(5310421009_A) SERIAL NBR: XXX
S-MODE ID: XXXXXXXX Source: Maintenance WD: XXX, XXX BITS: x111x111x111x111, x111x111x111x111 SF: 1,2,3,4, 1,2,3,4
FILE TYPE/PATH: software9 D:\CLDUProgrammer_Configuring_Package\SAFCLDUProgrammerStart_A.bat DATE: XXX
FILE TYPE/PATH: software3 C:\Program Files\Condor Engineering\CEI-DL615\bin\dl615_multi.exe DATE: XXX
FILE TYPE/PATH: config C:\Program Files\L-3 Com\LTE\Configurations\5310421009_A.xls DATE: XXX
FILE TYPE/PATH: download1 C:\Program Files\L-3 Com\LTE\Downloaded Data\ DATE: XXX
FILE TYPE/PATH: download2 C:\Program Files\L-3 Com\LTE\Downloaded Data\ DATE: XXX
FILE TYPE/PATH: download3 C:\Program Files\L-3 Com\LTE\Downloaded Data\ DATE: XXX
FILE TYPE/PATH: download4 C:\Program Files\L-3 Com\LTE\Downloaded Data\ DATE: XXX
FILE TYPE/PATH: software2 D:\RIOCLoader_Configuring_Package\SAFRIOCLoaderStart_C.bat DATE: XXX
FILE TYPE/PATH: software6 C:\Program Files\RUAG Aerospace\HDAS Uploader\uploader.exe DATE: XXX
FILE TYPE/PATH: software8 D:\HUD_Configuring_Package\HUDstartSAF_A.bat DATE: XXX
FILE TYPE/PATH: utility4 D:\LTE_Configuring_Package\DASU_Configuration_Table\5310421001_A.bin DATE: XXX
FILE TYPE/PATH: software1 D:\OSMC_Configuring_Package\OSMCstartSAF_A.bat DATE: XXX
FILE TYPE/PATH: software5 C:\Program Files\Kannad\KANNAD WINPROGR V2.0.3\KANNADWINPROGR.exe DATE: XXX
FILE TYPE/PATH: software4 C:\pc_tray_align\pc_tray_align.exe DATE: XXX
FILE TYPE/PATH: software7 D:\PDUOffset_Configuring_Package\PDUOffsetStart_A.bat DATE: XXX

Table 1: LTE (P/N 513.31.21.003/B) Configuration

- 1 Select Cancel.

NOTE: If the AMM is at Issue 2, Revision 3 or higher, use the Data Module listed below. If the AMM is not at Issue 2, Revision 3, use Appendix 1

- (3) Do the procedure to load the updated configuration table in the RIOCI 1, refer to the AMM 21-A-46-10-00-01A-750A-A.

The correct configuration for the RIOCI 1 table viewed on the MFD is:

- 5460421002, Rev. I

NOTE: If the AMM is at Issue 2, Revision 3 or higher, use the Data Module listed below. If the AMM is not at Issue 2, Revision 3, use Appendix 2

- (4) Do the procedure to load the updated configuration table in the RIOCI 2, refer to the AMM 21-A-46-10-00-02A-750A-A.

The correct configuration for the RIOCI 2 table viewed on the MFD is:

- 5460421002, Rev. I

NOTE: If the AMM is at Issue 2, Revision 3 or higher, use the Data Module listed below. If the AMM is not at Issue 2, Revision 3, use Appendix 3

- (5) Do the procedure to load the updated configuration table in the RIOCI 3, refer to the AMM 21-A-46-10-00-03A-750A-A.

The correct configuration for the RIOCI 3 table viewed on the MFD is:

- 5460421002, Rev. I

C. Close up

- (1) Remove all tools and materials. Make sure the work areas are clean.
- (2) Connect the electrical connector (P167) to the receptacle on the oxygen monitor (Ref. AMM, 21-A-35-40-02-00A-720A-A).
- (3) Do the test to make sure the modification is correct:
- (a) Connect the test switch (P/N 513.35.21.003) to the aircraft wiring as follows (Ref. Fig. 2 and Fig. 4):
- 1 Locate the terminal block TB030-05 in the rear cockpit, on the left side.
 - 2 Disconnect the wire W32F22 from terminal K of the TB030-05 (Ref. Hook-Up Chart, Fig. 4, Line 1).
 - 3 Connect the wire (which has the pin installed) from the test switch (P/N 513.35.21.003) to terminal K of the TB030-05 (Ref. Hook-Up Chart, Fig. 4, Line 2).
 - 4 Connect the wire (which has the in-line splice installed) from the test switch (P/N 513.35.21.003) to the wire W32F22 (Ref. Hook-Up Chart, Fig. 4, Line 3).
 - 5 Make sure the test switch (P/N 513.35.21.003) is set to the NORM position.

- (b) Before you do the work to the oxygen system, you must do the procedures shown in the AMM, 21-A-35-00-00-00A-012A-A.
- (c) Before you do the work to the Environmental Control System (ECS), you must do the procedures shown in the AMM, 21-A-21-00-00-00A-012A-A.
- (d) Before you do the work to the power plant, you must do the procedures shown in the AMM, 21-A-71-00-00-00A-012A-A.

NOTE: For the location of the access items, refer to AMM, 21-A-06-40-00-00A-055A-A.

- (e) Open the rear RH door ENG06 and the avionics-bay servicing-door, F17.
- (f) Disconnect the pipe between the P2.5 supply-pipe and the On-Board Oxygen-Generating System (OBOGS) heat exchanger, refer to AMM, 21-A-35-00-00-00A-344A-A.
- (g) Connect the adapter and the pipe of the test air adapter (P/N 513.35.09.001) to the pipe, refer to AMM, 21-A-35-00-00-00A-344A-A.

NOTE: For the location of the switches on the OXYGEN REGULATOR panel in the front cockpit, refer to AMM, 21-A-31-10-01-01A-040A-A.

- (h) Make sure the OXYGEN switch in the front cockpit is set to the OFF position.

NOTE: For the location of the switches on the OXYGEN REGULATOR panel in the rear cockpit, refer to 21-A-31-10-02-01A-040A-A.

- (i) Make sure the OXYGEN switch in the rear cockpit is set to the OFF position.
- (j) Connect the air supply to the air adapter test set (P/N 513.35.09.001).

CAUTION: DO NOT SUPPLY AIR PRESSURE OF MORE THAN 4,83 BAR (70 PSIG) TO THE OBOGS . IF YOU SUPPLY A PRESSURE OF MORE THAN 4,83 BAR (70 PSIG), DAMAGE TO SYSTEM-COMPONENTS CAN OCCUR.

- (k) Set the air supply to give a pressure of 2,07 bar (30 psig).
- (l) Energize the aircraft electrical system, refer to AMM, 21-A-24-40-00-00A-331A-A.

NOTE: For the location of the MC/HUD switch, refer to AMM, 21-A-31-10-01-08A-040A-A.

- (m) Set the MC/HUD switch to the MC position.

NOTE: For more information on the Multi-Functional Display (MFD) ECS page, refer to 21-A-46-31-04-00A-040A-A.

- (n) Push the ECS soft key on the MFD.

(o) Use the OXYGEN REGULATOR panel in the front cockpit and a stopwatch to do the steps that follow at the same time:

- Set the OXYGEN switch to the ON position
- Start the stopwatch.

NOTE: For more information on the Dedicated Warning Panel (DWP), refer to 21-A-31-50-01-00A-040A-A.

(p) Make sure that:

- The RED OXY caption on the ECS page shows
- The RED OXY caption on the DWP shows
- The OBOGS brick symbol on the ECS page is red.

(q) When the red OXY caption goes off, stop the stopwatch.

(r) Make a record of the time shown on the stopwatch.

(s) Make sure that the time is less than three minutes.

(t) When the OBOGS has started, do this test:

1 Set the test switch (P/N 513.35.21.003) to the OFF position.

2 Make sure that:

- The RED OXY caption on the ECS page comes on
- The RED OXY caption on the DWP comes on
- The OBOGS brick symbol on the ECS page turns red.

3 Set the test switch to the NORM position.

4 Set the OXYGEN switch on the OXYGEN REGULATOR panel in the front cockpit to the OFF position and then to the ON position.

5 Make sure that:

- The RED OXY caption on the ECS page does not show
- The RED OXY caption on the DWP does not show
- The OBOGS brick symbol on the ECS page is green.

(u) Set the OXYGEN switch on the OXYGEN REGULATOR panel in the front cockpit to the OFF position.

(v) Set the MC/HUD switch to the OFF position.

(w) De-energize the aircraft electrical system, refer to AMM, 21-A-24-40-00-00A-332A-A.

(x) Disconnect the test switch (P/N 513.35.21.003) from the aircraft wiring as follows (Ref. Fig. 2 and Fig. 4):

- 1 Disconnect the wire (which has the in-line splice installed) from the wire W32F22 (Ref. Hook-Up Chart, Fig. 4, Line 4).
- 2 Disconnect the wire (which has the pin installed) from the terminal K of the TB030-05 (Ref. Hook-Up Chart, Fig. 4, Line 5).
- 3 Connect the wire W32F22 to terminal K of the TB030-05 (Ref. Hook-Up Chart, Fig. 4, Line 6).

(4) Do the function test of the oxygen system, refer to 21-A-35-00-00-00A-344A-A.

NOTE: Some of the set-up steps called up in the functional test have been already been done in Step 3.C.(3).

(5) Install the rear cockpit, lower-left rear-panel (Ref. AMM, 21-A-25-10-00-00A-040A-A).

(6) Install the rear ejection seat (Ref. AMM, 21-A-95-10-00-00A-720A-A).

D. Documentation

- (1) Make an entry in the Aircraft Logbook that this Service Bulletin has been incorporated.
- (2) Use the Service Bulletin Evaluation Sheet and report your results and the serial number of the aircraft to PILATUS.

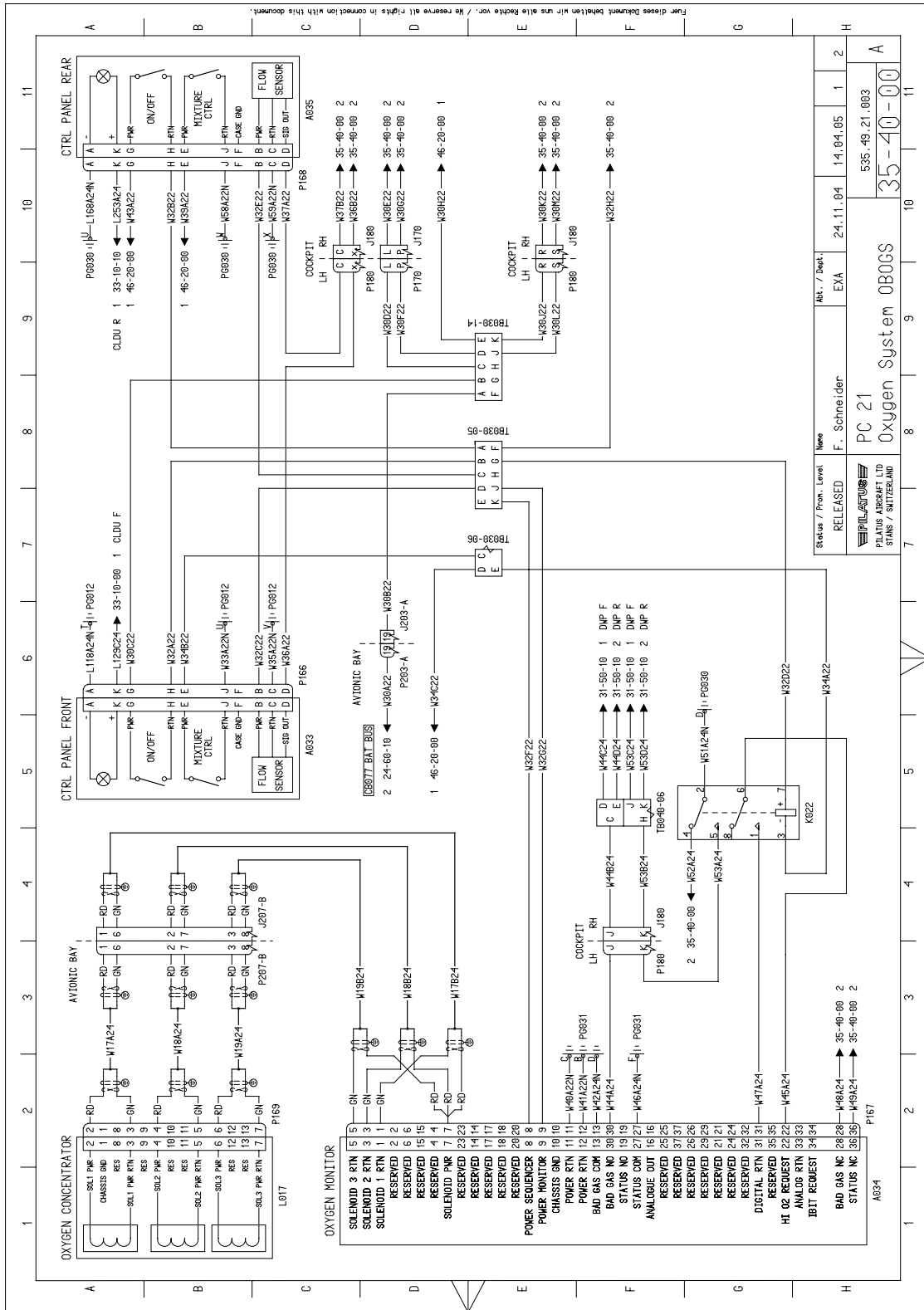

Wiring Diagram (Pre-Service Bulletin 35-002)
Figure 1

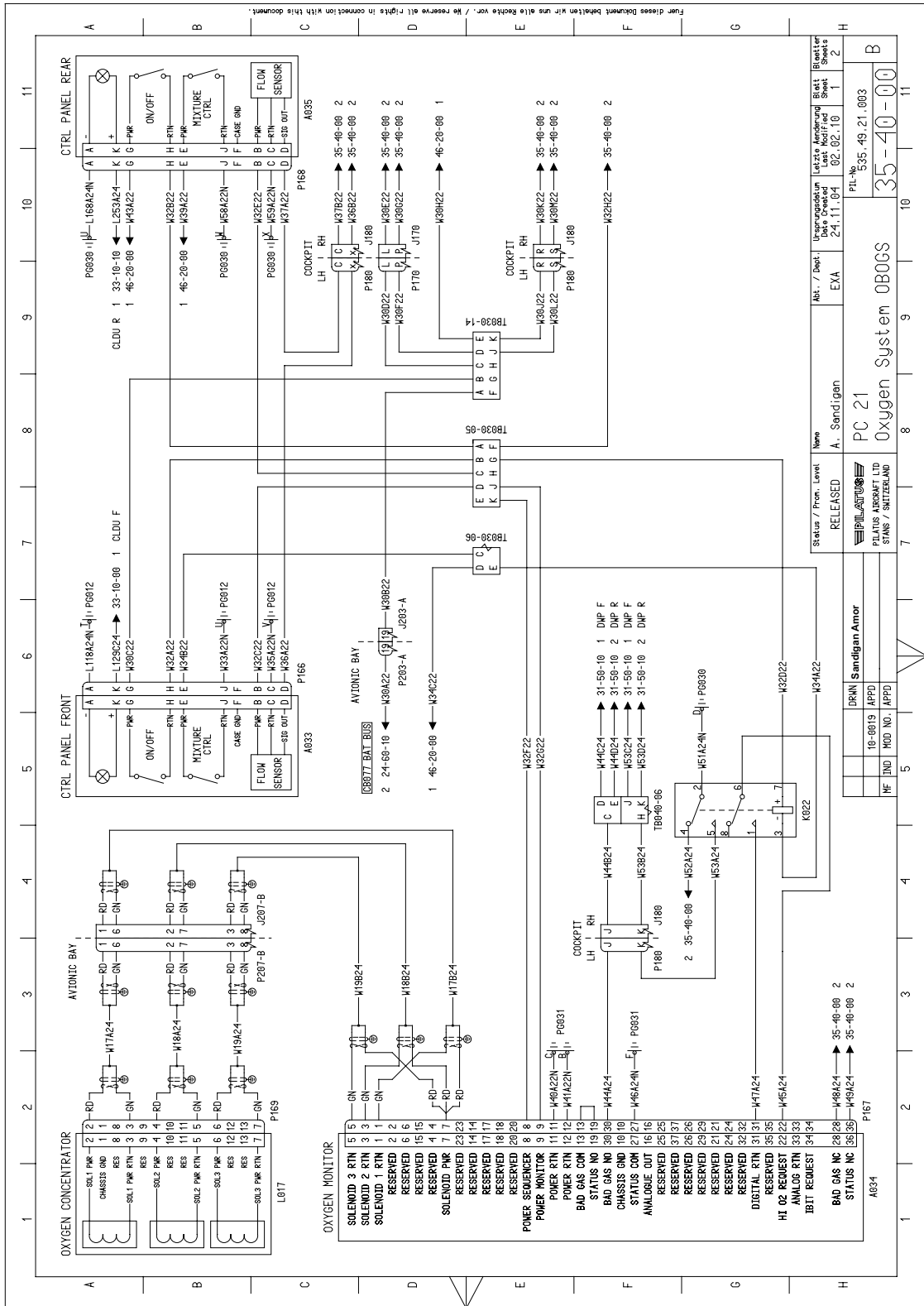

Wiring Diagram (Post Service Bulletin 35-002)

Figure 2

Line	End 1			Wire No.	Color	End 2			Remarks	
	Ident. No.	Terminal No.	Terminal P/N.			Terminal P/N.	Terminal No.	Ident. No.		
1	P167	13	-	W42A24N	-	-	-	D	PG031	Disconnect Ends 1 and 2, remove wire
2	P167	13	971.75.17.903	Note 1	-	Note 2	Note 2	19	P167	New wire. Connect Ends 1 and 2

NOTE 1: Use the Operator supplied wire P/N 919.79.41.301.

NOTE 2: Use the pin from the related terminal of the plug P167.

Hook-Up Chart
Figure 3

Line	End 1			Wire No.	Color	End 2			Remarks
	Ident. No.	Terminal No.	Terminal P/N.			Terminal P/N.	Terminal No.	Ident. No.	
1	TB030-05	K	-	W32F22	-	-	8	P167	Disconnect End 1
2	TB030-05	K	-	-	-	-	Wire with pin installed on the end (Part of Test Switch P/N 513.35.21.003)		Connect End 2 to End 1
3	P167	8	-	W32F22	-	-	Wire with in-line splice installed on the end (Part of Test Switch P/N 513.35.21.003)		Connect End 2 to wire from End 1
4	P167	8	-	W32F22	-	-	Wire with in-line splice installed on the end (Part of Test Switch P/N 513.35.21.003)		Disconnect End 2 from the wire from End 1
5	TB030-05	K	-	-	-	-	Wire with pin installed on the end (Part of Test Switch P/N 513.35.21.003)		Disconnect End 2 from End 1
6	TB030-05	K	-	W32F22	-	-	8	P167	Connect the wire to End 1

 Hook-Up Chart
 Figure 4

INTENTIONALLY BLANK

Appendix 1

RIOC 1 - LOAD SOFTWARE PROCEDURES

WARNING: MAKE SURE THE SAFETY PIN IS INSTALLED IN THE EJECTION SEAT FIRING-HANDLE AND THE CFS BEFORE YOU DO WORK IN THE COCKPIT. IF THE SAFETY PIN IS NOT INSTALLED, YOU CAN OPERATE THE EJECTION SEAT OR THE CFS ACCIDENTALLY. THE EJECTION SEAT AND THE CFS CAN KILL OR CAUSE AN INJURY TO PERSONNEL AND CAN CAUSE DAMAGE TO EQUIPMENT.

1. Support equipment

Identification No.	Nomenclature	Qty
513.31.21.003	LINE TEST EQUIPMENT (LTE) BASIC KIT SAF	1
513.31.21.005	LTE SUPPORT EQUIPMENT SAF	1

NOTE: The LTE Basic Kit (P/N 513.31.21.003) has the components that follow for the RIOC software load procedure:

- The Notebook
- The LTE Configuration Files Compact Disk (CD).

NOTE: The LTE Support Equipment (P/N 513.31.21.005) has the components that follow for the RIOC software load procedure:

- The RIOC Maintenance Cable
- The Edgeport USB Adapter.

2. Procedure

A. Preparation.

- (1) Before you do work to the electrical system, you must do the safety procedures shown in the the AMM, 21-A-24-00-00-00A-012A-A.
- (2) Energize the aircraft electrical system (Ref. AMM 21-A-24-40-00-00A-331A-A).
- (3) Connect the RIOC maintenance cable P807-A connector to the J500 connector in the front cockpit.
- (4) Connect the RIOC maintenance cable P806-A to the USB Adapter.
- (5) Connect the USB Adapter to Notebook.

B. Load Procedure.

- (1) Power up the notebook.
- (2) Put the LTE Configuration Files CD in the CD drive of the notebook.
- (3) Double click the LTE icon (Ref. Fig 1, Item 1) to start the LTE software.

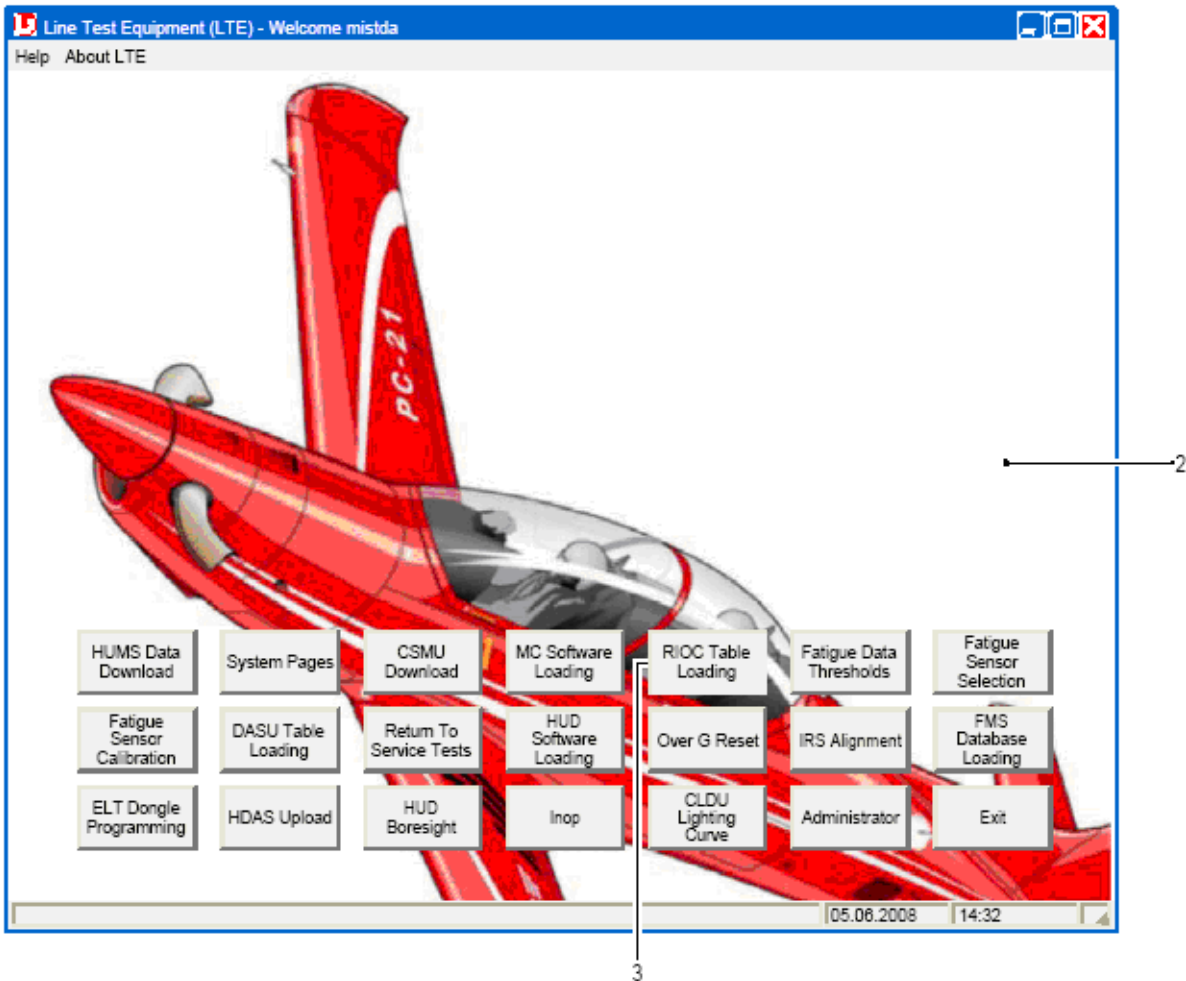

Figure 1

- (4) Select the RIOC Table Loading button (Ref. Fig 1, Item 3).
- (5) Click on the Yes button on the Utility Launch pop up box.
- (6) When prompted, select the aircraft tail number from the drop down menu, then click OK.

NOTE: For the location of the access items, refer to AMM, 21-A-06-40-00-00A-055A-A.

- (7) Open the right avionics-bay servicing-door, F17.
- (8) Open, then close the circuit breaker RIOC 1 (B10) in the avionics bay to set the RIOC 1 off then on again.

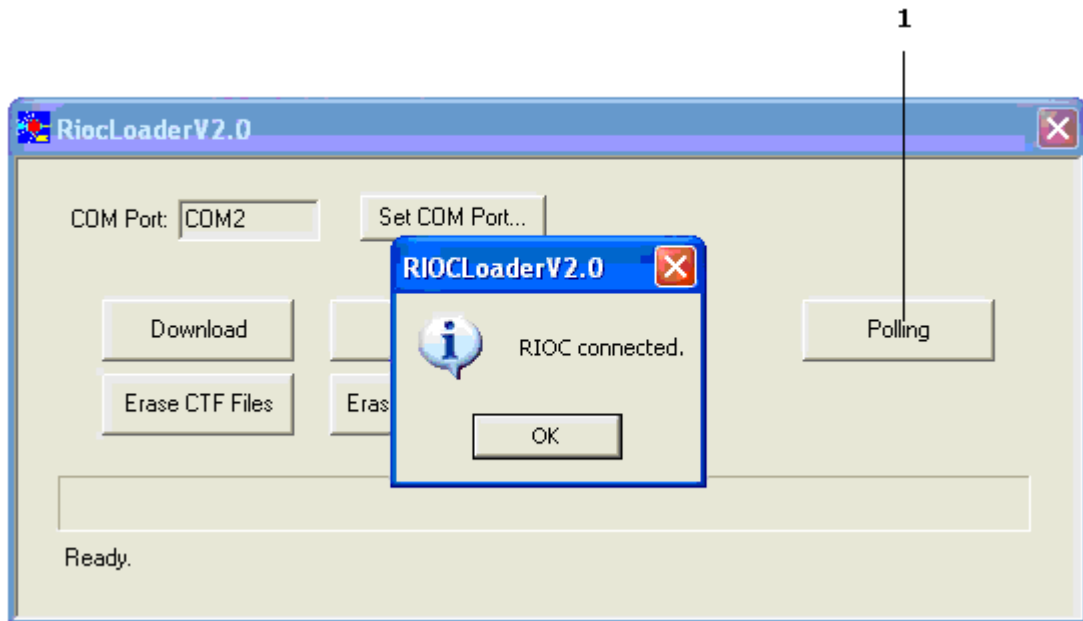

Figure 2

- (9) Wait 20 seconds, then select the Polling button (Ref. Fig 2, Item 1).

NOTE: When the “RIOC not connected” error message is shown on the RIOC Loader V2.0 dialog box, do a check of the connections and do Step 2.B.(9) again.

- (10) Make sure that the “RIOC connected” message is shown on the RIOC Loader V2.0 dialog box (Ref. Fig 2), then click OK.

NOTE: The RIOC configuration files are stored in the RIOCT folder on the LTE Configuration Files CD. The RIOC Loader V2.0 software automatically points to this folder.

- (11) For RIOCT 1 you must download the files that follow:

- The RIOCT 1 configuration file: ctf1.ctf
- The RIOCT 2 configuration file: ctf2.ctf
- The RIOCT 3 configuration file: ctf3.ctf.

- (12) For each configuration file that must be downloaded do Step 2.B.(12)(a) thru (c).

- (a) Select the Download button (Ref. Fig 3, Item 1).
- (b) In the OPEN window pop up box, select the correct configuration file and select the OPEN button.
- (c) When the download is correctly ended, click OK.

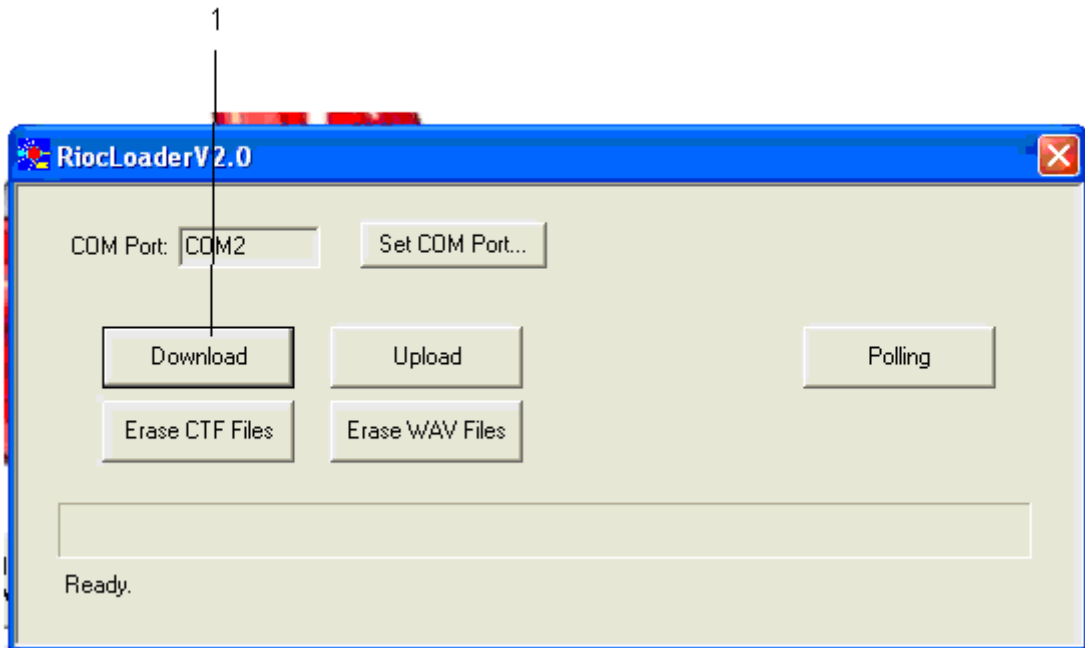

Figure 3

- (13) On the LTE main window, select the Exit button.
- (14) Disconnect the RIOC maintenance cable P807-A from the J500 connector in the front cockpit.
- (15) Open, then close the circuit breaker RIOC 1 (B10) in the avionics bay to set the RIOC 1 off then on again.
 - NOTE:** For the location of the MC/HUD switch in the front cockpit, refer to the AMM, 21-A-31-10-01-08A-040A-A.
- (16) Set the MC/HUD switch to the MC position.
 - NOTE:** For more information on the Multi-Function Display (MFD) MAINT page, refer to the AMM, 21-A-46-31-08-01A-040A-A.
- (17) Push the SYS, MAINT soft keys on the left MFD in the front cockpit.
- (18) Make sure that the MFD MAINT page shows the correct RIOC1 software part number (5460421002/I).
- (19) Set the MC/HUD switch to the OFF position.

C. Job Close-Up

- (1) De-energize the aircraft electrical system (Ref. AMM, 21-A-24-40-00-00A-332A-A).
- (2) Disconnect the RIOC maintenance cable from the USB adapter.
- (3) Disconnect the USB adapter from the notebook.
- (4) Close all the software on the notebook.
- (5) Remove the LTE Configuration files CD from the CD drive of the notebook.
- (6) Power down the notebook.

NOTE: For the location of the access items, refer to AMM, 21-A-06-40-00-00A-055A-A.

- (7) Close the right avionics-bay servicing-door, F17.

INTENTIONALLY BLANK

Appendix 2

RIOC 2 - LOAD SOFTWARE PROCEDURES

WARNING: MAKE SURE THE SAFETY PIN IS INSTALLED IN THE EJECTION SEAT FIRING-HANDLE AND THE CFS BEFORE YOU DO WORK IN THE COCKPIT. IF THE SAFETY PIN IS NOT INSTALLED, YOU CAN OPERATE THE EJECTION SEAT OR THE CFS ACCIDENTALLY. THE EJECTION SEAT AND THE CFS CAN KILL OR CAUSE AN INJURY TO PERSONNEL AND CAN CAUSE DAMAGE TO EQUIPMENT.

1. Support equipment

Identification No.	Nomenclature	Qty
513.31.21.003	LINE TEST EQUIPMENT (LTE) BASIC KIT SAF	1
513.31.21.005	LTE SUPPORT EQUIPMENT SAF	1

NOTE: The LTE Basic Kit (P/N 513.31.21.003) has the components that follow for the RIOC software load procedure:

- The Notebook
- The LTE Configuration Files Compact Disk (CD).

NOTE: The LTE Support Equipment (P/N 513.31.21.005) has the components that follow for the RIOC software load procedure:

- The RIOC Maintenance Cable
- The Edgeport USB Adapter.

2. Procedure

A. Preparation.

- (1) Before you do work to the electrical system, you must do the safety procedures shown in the AMM, 21-A-24-00-00-00A-012A-A.
- (2) Energize the aircraft electrical system (Ref. AMM 21-A-24-40-00-00A-331A-A).
- (3) Connect the RIOC maintenance cable P807-A connector to the J501 connector in the front cockpit.
- (4) Connect the RIOC maintenance cable P806-B to the USB Adapter.
- (5) Connect the USB Adapter to Notebook.

B. Load Procedure.

- (1) Power up the notebook.
- (2) Put the LTE Configuration Files CD in the CD drive of the notebook.
- (3) Double click the LTE icon (Ref. Fig 1, Item 1) to start the LTE software.

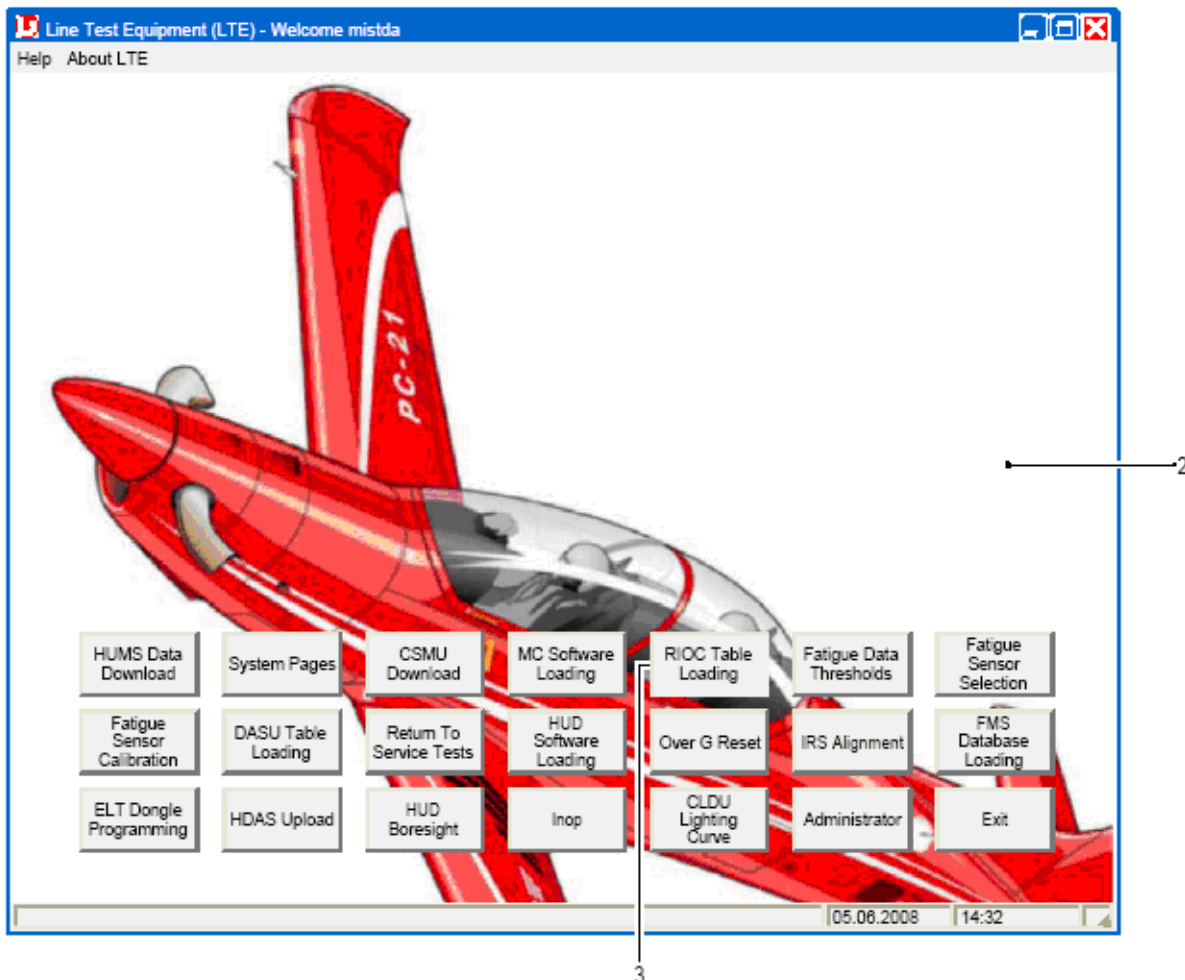
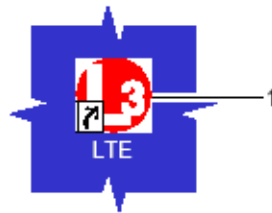

Figure 1

- (4) Select the RIOC Table Loading button (Ref. Fig 1, Item 3).
 - (5) Click on the Yes button on the Utility Launch pop up box.
 - (6) When prompted, select the aircraft tail number from the drop down menu, then click OK.
- NOTE:** For the location of the access items, refer to AMM, 21-A-06-40-00-00A-055A-A.
- (7) Open the right avionics-bay servicing-door, F17.
 - (8) Open, then close the circuit breaker RIOC 2 (B13) in the avionics bay to set the RIOC 2 off then on again.

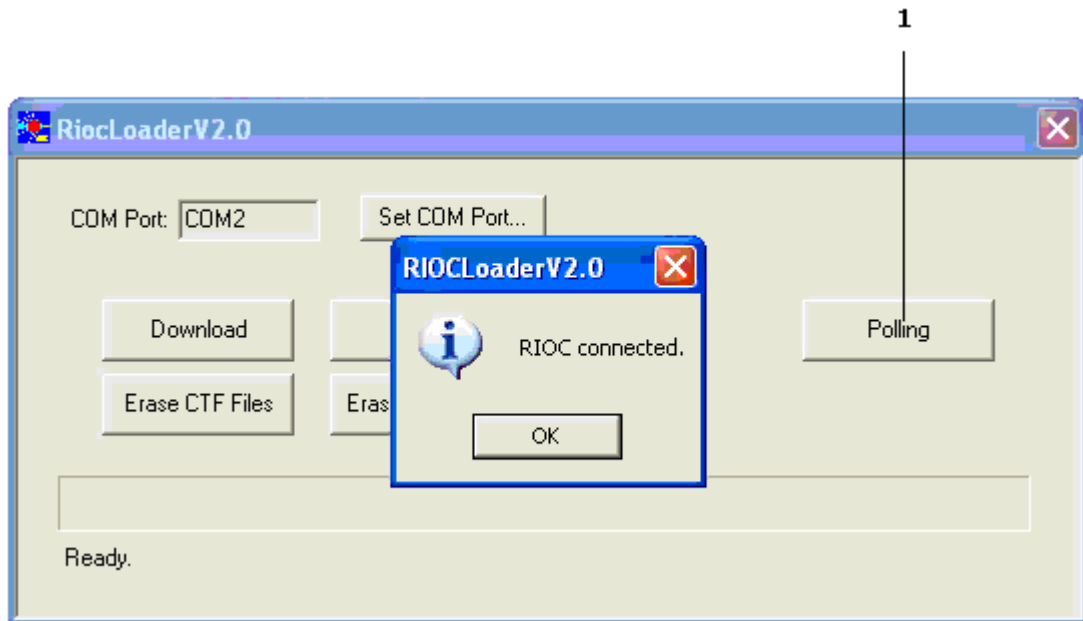

Figure 2

- (9) Wait 20 seconds, then select the Polling button (Ref. Fig 2, Item 1).

NOTE: When the “RIOCI not connected” error message is shown on the RIOCI Loader V2.0 dialog box, do a check of the connections and do Step 2.B.(9) again.

- (10) Make sure that the “RIOCI connected” message is shown on the RIOCI Loader V2.0 dialog box (Ref. Fig 2), then click OK.

NOTE: The RIOCI configuration files are stored in the RIOCI_CT folder on the LTE Configuration Files CD. The RIOCI Loader V2.0 software automatically points to this folder.

- (11) For RIOCI 2 you must download the files that follow:

- The RIOCI 1 configuration file: ctf1 1.ctf
- The RIOCI 2 configuration file: ctf1 2.ctf
- The RIOCI 3 configuration file: ctf1 3.ctf.

- (12) For each configuration file that must be downloaded do Step 2.B.(12)(a) thru (c).

- (a) Select the Download button (Ref. Fig 3, Item 1).
- (b) In the OPEN window pop up box, select the correct configuration file and select the OPEN button.
- (c) When the download is correctly ended, click OK.

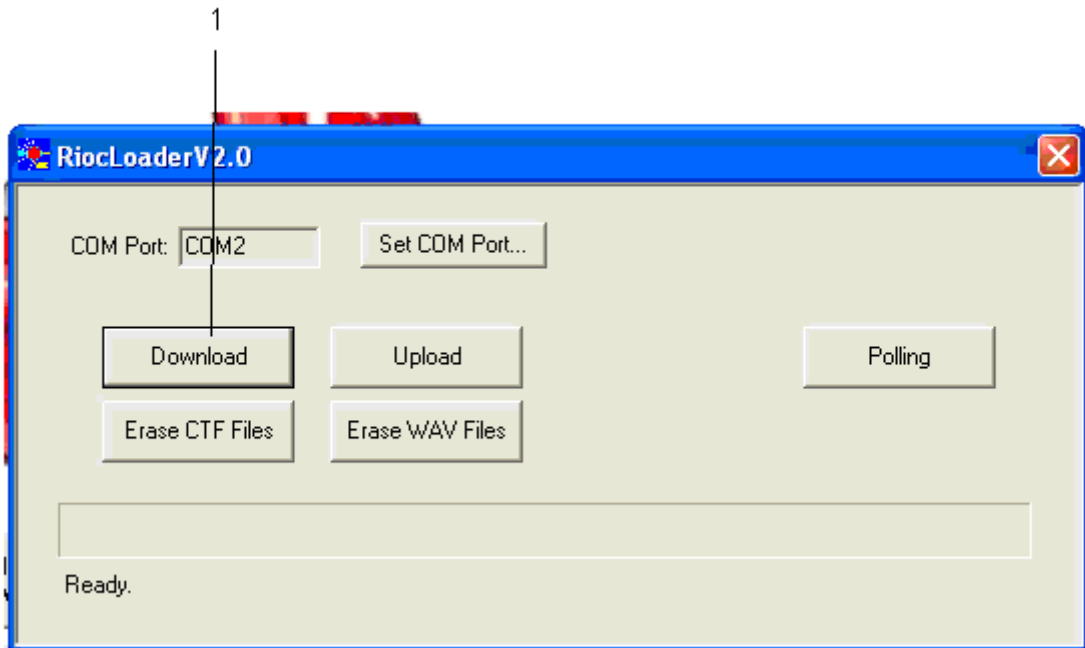

Figure 3

- (13) On the LTE main window, select the Exit button.
- (14) Disconnect the RIOC maintenance cable P807-A from the J500 connector in the front cockpit.
- (15) Open, then close the circuit breaker RIOC 2 (B13) in the avionics bay to set the RIOC 2 off then on again.
 - NOTE:** For the location of the MC/HUD switch in the front cockpit, refer to AMM, 21-A-31-10-01-08A-040A-A.
- (16) Set the MC/HUD switch to the MC position.
 - NOTE:** For more information on the Multi-Function Display (MFD) MAINT page, refer to AMM, 21-A-46-31-08-01A-040A-A.
- (17) Push the SYS, MAINT soft keys on the left MFD in the front cockpit.
- (18) Make sure that the MFD MAINT page shows the correct RIOC2 software part number (P/N 5460421002/I).
- (19) Set the MC/HUD switch to the OFF position.

C. Job Close-Up

- (1) De-energize the aircraft electrical system (Ref. AMM, 21-A-24-40-00-00A-332A-A).
- (2) Disconnect the RIOC maintenance cable from the USB adapter.
- (3) Disconnect the USB adapter from the notebook.
- (4) Close all the software on the notebook.
- (5) Remove the LTE Configuration files CD from the CD drive of the notebook.
- (6) Power down the notebook.

NOTE: For the location of the access items, refer to AMM, 21-A-06-40-00-00A-055A-A.

- (7) Close the right avionics-bay servicing-door, F17.

INTENTIONALLY BLANK

Appendix 3

RIOC 3 - LOAD SOFTWARE PROCEDURES

WARNING: MAKE SURE THE SAFETY PIN IS INSTALLED IN THE EJECTION SEAT FIRING-HANDLE AND THE CFS BEFORE YOU DO WORK IN THE COCKPIT. IF THE SAFETY PIN IS NOT INSTALLED, YOU CAN OPERATE THE EJECTION SEAT OR THE CFS ACCIDENTALLY. THE EJECTION SEAT AND THE CFS CAN KILL OR CAUSE AN INJURY TO PERSONNEL AND CAN CAUSE DAMAGE TO EQUIPMENT.

1. Support equipment

Identification No.	Nomenclature	Qty
513.31.21.003	LINE TEST EQUIPMENT (LTE) BASIC KIT SAF	1
513.31.21.005	LTE SUPPORT EQUIPMENT SAF	1

NOTE: The LTE Basic Kit (P/N 513.31.21.003) has the components that follow for the RIOC software load procedure:

- The Notebook
- The LTE Configuration Files Compact Disk (CD).

NOTE: The LTE Support Equipment (P/N 513.31.21.005) has the components that follow for the RIOC software load procedure:

- The RIOC Maintenance Cable
- The Edgeport USB Adapter.

2. Procedure

A. Preparation.

- (1) Before you do work to the electrical system, you must do the safety procedures shown in the AMM, 21-A-24-00-00-00A-012A-A.
- (2) Energize the aircraft electrical system (Ref. AMM 21-A-24-40-00-00A-331A-A).
NOTE: For the location of the access items, refer to AMM, 21-A-06-40-00-00A-055A-A.
- (3) Open the baggage bay servicing-door, F18.
- (4) Connect the RIOC maintenance cable P807-A connector to the J509 (CAT8) connector in the baggage bay.
- (5) Connect the RIOC maintenance cable P806-A to the USB Adapter.
- (6) Connect the USB Adapter to Notebook.

B. Load Procedure.

- (1) Power up the notebook.

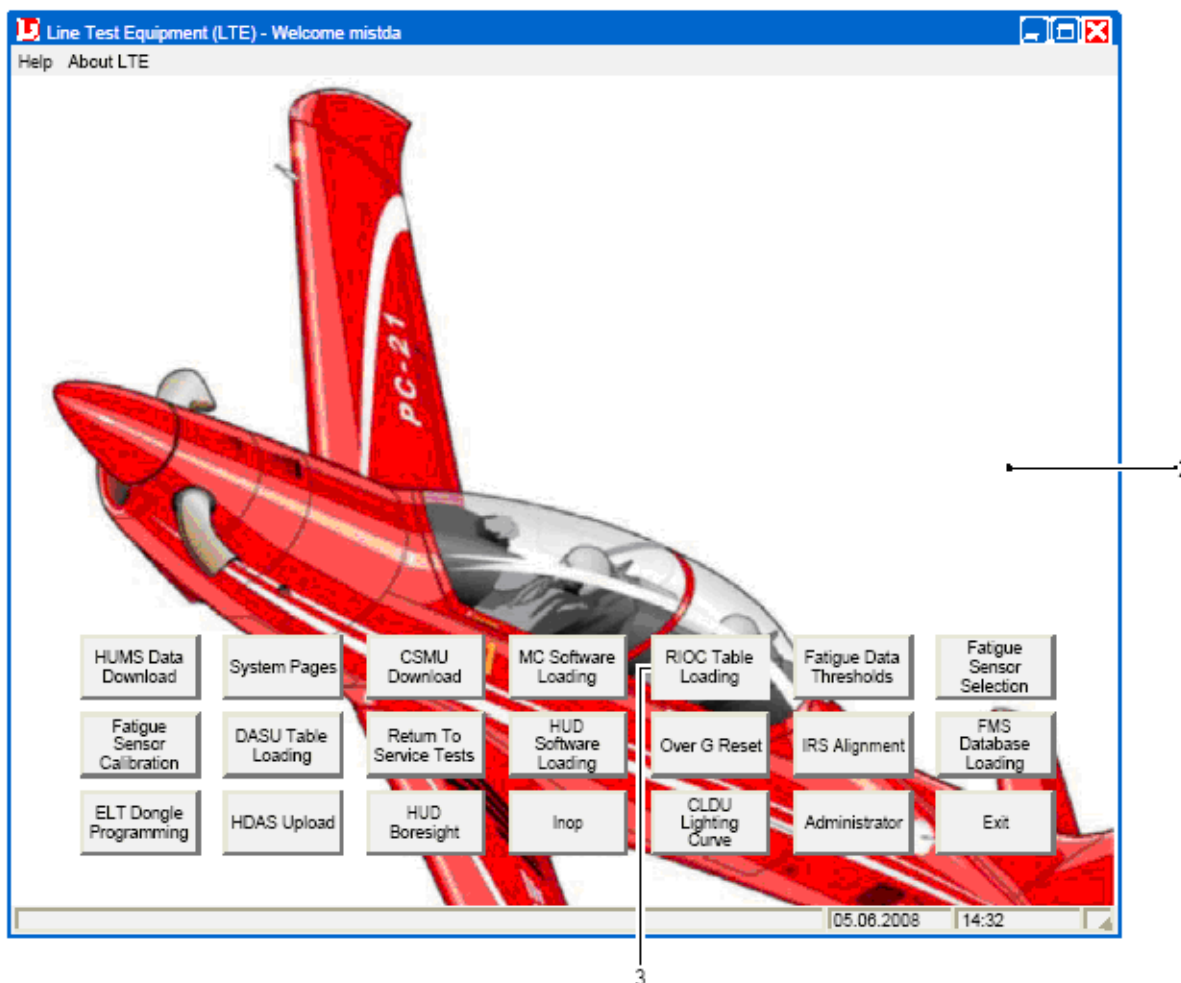

Figure 1

- (2) Put the LTE Configuration Files CD in the CD drive of the notebook.
- (3) Double click the LTE icon (Ref. Fig 1, Item 1) to start the LTE software.
- (4) Select the RIOCC Table Loading button (Ref. Fig 1, Item 3).
- (5) Click on the Yes button on the Utility Launch pop up box.
- (6) When prompted, select the aircraft tail number from the drop down menu, then click OK.

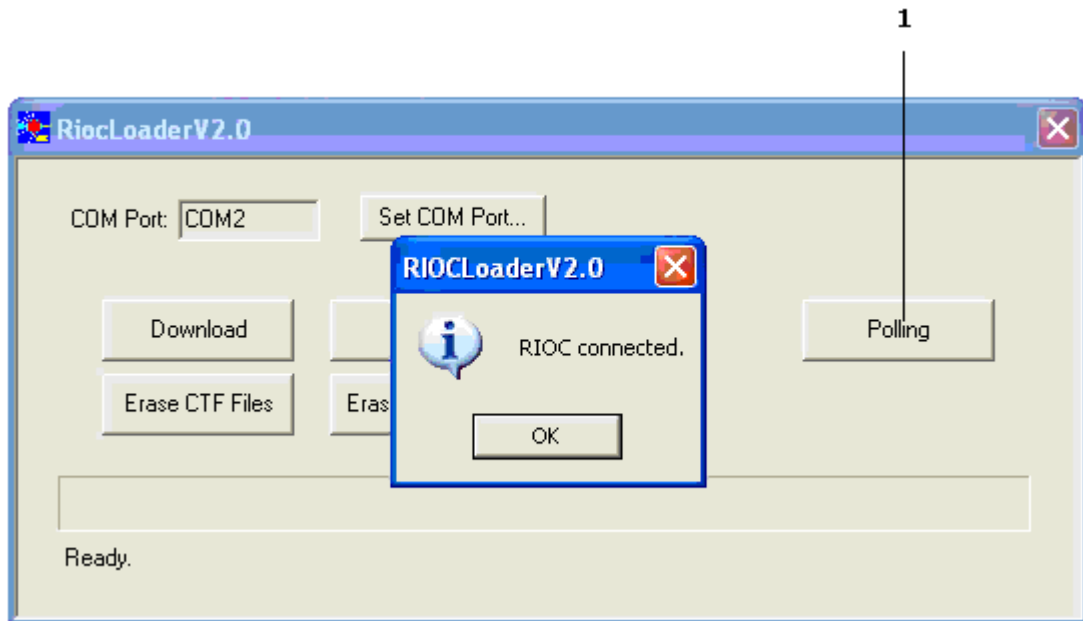

Figure 2

NOTE: For the location of the access items, refer to AMM, 21-A-06-40-00-00A-055A-A.

- (7) Open the right avionics-bay servicing-door, F17.
- (8) Open, then close the circuit breaker RIOCL 3 (B16) in the avionics bay to set the RIOCL 3 off then on again.
- (9) Wait 20 seconds, then select the Polling button (Ref. Fig 2, Item 1).

NOTE: When the “RIOCL not connected” error message is shown on the RIOCL Loader V2.0 dialog box, do a check of the connections and do Step 2.B.(9) again.

- (10) Make sure that the “RIOCL connected” message is shown on the RIOCL Loader V2.0 dialog box (Ref. Fig 2), then click OK.

NOTE: The RIOCL configuration files are stored in the RIOCL_CT folder on the LTE Configuration Files CD. The RIOCL Loader V2.0 software automatically points to this folder.

- (11) For RIOCL 3 you must download the files that follow:
 - The RIOCL 1 configuration file: ctf1 1.ctf
 - The RIOCL 2 configuration file: ctf1 2.ctf
 - The RIOCL 3 configuration file: ctf1 3.ctf.
- (12) For each configuration file that must be downloaded do Step 2.B.(12)(a) thru (c).
 - (a) Select the Download button (Ref. Fig 3, Item 1).
 - (b) In the OPEN window pop up box, select the correct configuration file and select the OPEN button.

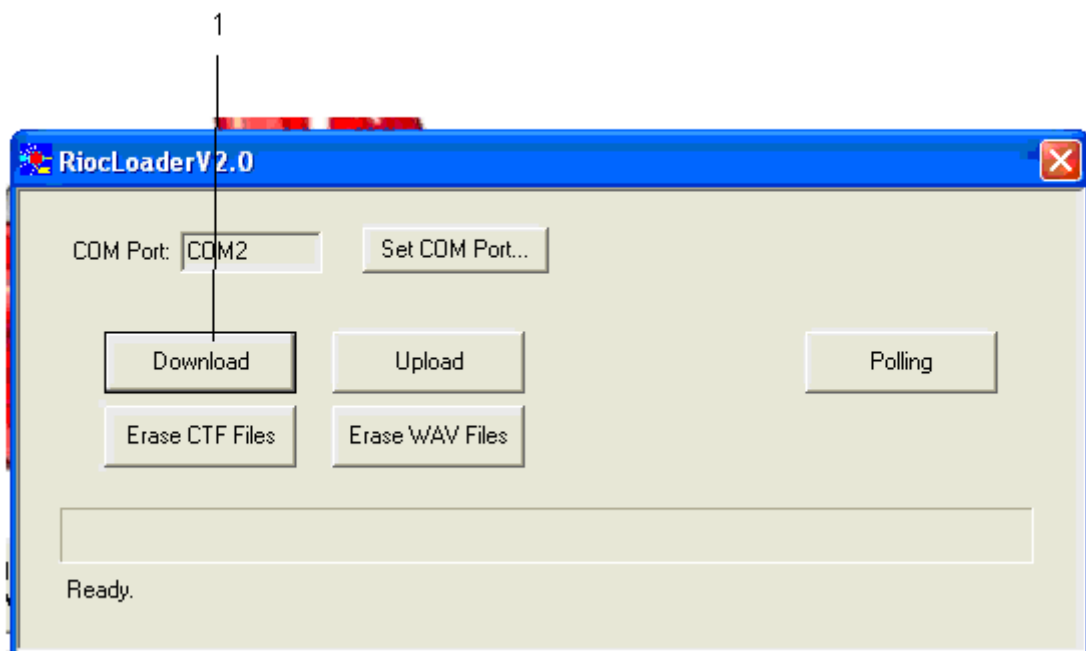

Figure 3

- (c) When the download is correctly ended, click OK.
- (13) On the LTE main window, select the Exit button.
- (14) Connect the RIOCI maintenance cable P807-A connector to the J501 connector in the baggage bay.
- (15) Open, then close the circuit breaker RIOCI 3 (B16) in the avionics bay to set the RIOCI 3 off then on again.
- NOTE:** For the location of the MC/HUD switch in the front cockpit, refer to AMM, 21-A-31-10-01-08A-040A-A.
- (16) Set the MC/HUD switch to the MC position.
- NOTE:** For more information on the Multi-Function Display (MFD) MAINT page, refer to AMM, 21-A-46-31-08-01A-040A-A.
- (17) Push the SYS, MAINT soft keys on the left MFD in the front cockpit.
- (18) Make sure that the MFD MAINT page shows the correct RIOCI3 software part number (P/N 5460421002/I).
- (19) Set the MC/HUD switch to the OFF position.

C. Job Close-Up

- (1) De-energize the aircraft electrical system (Ref. AMM, 21-A-24-40-00-00A-332A-A).
- (2) Disconnect the RIOC maintenance cable from the USB adapter.
- (3) Disconnect the USB adapter from the notebook.
- (4) Close all the software on the notebook.
- (5) Remove the LTE Configuration files CD from the CD drive of the notebook.
- (6) Power down the notebook.

NOTE: For the location of the access items, refer to AMM, 21-A-06-40-00-00A-055A-A.

- (7) Close the right avionics-bay servicing-door, F17 and the baggage bay servicing-door, F18.

INTENTIONALLY BLANK

SERVICE BULLETIN EVALUATION SHEET FOR SB No. 35-002			
Title	Oxygen - On-Board Oxygen-Generating system (OBOGS) Do the Modification to the OBOGS Warning Configuration		
Customer			
Service Center			
EMBODIMENT REPORTING			
This SB has been embodied:		<input type="checkbox"/>	On the entire fleet
		<input type="checkbox"/>	Only partially
Provide embodiment details per aircraft (use additional copies of this table, if necessary)			
MSN	Flying Hours	MSN	Flying Hours
Additional embodiment comments/findings			
EDITORIAL COMMENTS (procedure, kit quality, suggested improvements, etc.)			
Name	Signature	Date	
Please complete and forward this form to: Pilatus Aircraft LTD, Customer Technical Support (MCC), P.O. BOX 992, 6371 Stans, Switzerland Fax: +41 (0)41 619 6773 Email: Techsupport@pilatus-aircraft.com			

SERVICE BULLETIN EVALUATION SHEET

INTENTIONALLY BLANK