

Lufttüchtigkeitsanweisung
Consigne de navigabilité
Prescrizione di aeronavigabilità
Airworthiness directive

HB 94-086

Inkraftsetzung
Mise en vigueur
Entrata in vigore
Effective Date

06.04.1994

Betroffene Muster - Types concernés - Applicabilità - Models affected

PILATUS AIRCRAFT LTD. - All PC-6 aircraft from serial number 825 through 892 inclusive.

Anlass/Massnahmen - Objet/Mesures - Oggetto/Provvedimenti - Subject/Action

HORIZONTAL STABILIZER HINGE BRACKETS

- Initial and repetitive inspections.
- Detailed inspection.
- Modification if necessary.

Fristen - Délais - Scadenza - Compliance

The effective date on this page is applicable.
Compliance in accordance with Pilatus Service Bulletin No. PC-6 165.

Herkunft - Provenance - Provenienza - Origin

Bezugnahme - Référence - Riferimento - Reference

Pilatus Service Bulletin PC-6 165, dated February 07, 1994, which is an integral part of this Airworthiness Directive.

Bemerkungen - Observations - Osservazioni - Remarks

Note: The Pilatus Service Bulletin PC6- 165 is attached in its entirety.

Rechtsmittelbelehrung	siehe TM Nr.		Seite	von
Voies de droit	voir CT no.	F 80.015-10	Page	de
Rimedi giuridici	vedi CT no.		Pagina	di
Right to appeal	see CT no.		Page	of

SERVICE BULLETIN

SERVICE BULLETIN NO: PC-6 165
MODIFICATION NO:

REF NO:
ATA CHAPTER: 55

INSPECTION OF - HORIZONTAL STABILIZER - HINGE BRACKETS.

1. PLANNING INFORMATION

A. Effectivity

- (1) All PC-6 aircraft from MSN 825 thru 892 inclusive.
- (2) This Service Bulletin will be incorporated on aircraft MSN 893 and all subsequent aircraft.

B. Reason

Instances of rivets shearing, on the hinge brackets which attach the horizontal stabilizer to the fuselage, have occurred. All Operators must inspect their PC-6 aircraft, before the next flight and thereafter as an after-flight inspection, to make sure that no rivets have sheared during the previous flight. This inspection must continue until the next 100 hour inspection when the horizontal stabilizer must be removed and the brackets position checked with a 15 mm spacer. Where force has to be used to position the spacer - then both brackets must be re-positioned in accordance to this Service Bulletin.

C. Description

Accomplishment of this Service Bulletin consists of completing the following tasks:

- (1) Do an inspection of the hinge brackets of the horizontal stabilizer before the next flight.
- (2) Do an inspection of the hinge brackets of the horizontal stabilizer, after each consecutive flight, until the next 100 hour inspection.
- (3) At the 100 hour inspection, with the horizontal stabilizer removed, do a detailed inspection on the hinge brackets using a 15 mm spacer.
- (4) Should any force be needed to position the spacer in either of the hinge brackets then BOTH the hinge brackets must be removed, re-positioned using the 15 mm spacer and put back with oversize rivets.

D. Compliance

Mandatory.

E. Approval

The technical aspects of this Service Bulletin have been approved by the Federal Office for Civil Aviation (FOCA) of Switzerland and is issued as an Airworthiness Directive.

PILATUS
PC-6
SERVICE BULLETIN

2. ACCOMPLISHMENT INSTRUCTIONS

A. Before Next Flight Inspection

WARNING: IF ANY SHEARED RIVETS ARE FOUND, THE MODIFICATION (REF. PARA. C) MUST BE CARRIED OUT, ON BOTH HINGE BRACKETS, PRIOR TO THE NEXT FLIGHT.

- (1) Lift the RH hinged-spring panel (FT3) and inspect the hinge bracket [6 rivets] (Ref. Fig. 1).

NOTE: No sheared or loose rivets - hinge bracket serviceable.

- (2) Lift the LH hinged-spring panel (FT2) and inspect the hinge bracket [5 rivets].

NOTE: No sheared or loose rivets - hinge bracket serviceable.

B. After-flight Inspection

WARNING: IF ANY SHEARED RIVETS ARE FOUND, THE MODIFICATION (REF. PARA. C) MUST BE CARRIED OUT, ON BOTH HINGE BRACKETS, PRIOR TO THE NEXT FLIGHT.

- (1) Lift the RH hinged-spring panel (FT3) and inspect the hinge bracket [6 rivets] (Ref. Fig. 1).

NOTE: No sheared or loose rivets - hinge bracket serviceable.

- (2) Lift the LH hinged-spring panel (FT2) and inspect the hinge bracket [5 rivets].

NOTE: No sheared or loose rivets - hinge bracket serviceable.

C. Check

- (1) Manufacture a 15 (+0.2/-0.0) mm spacer which has an 8 mm clearance hole through the centre. The material may be light-alloy or steel.

WARNING: MAKE SURE THAT THE HORIZONTAL STABILIZER AND ELEVATOR UNITS ARE SUPPORTED DURING REMOVAL AND INSTALLATION.

- (2) Prepare the aircraft for servicing.
- (3) Set the horizontal stabilizer to give full nose up trim.
- (4) Open and install a safety clip to circuit breaker STAB TRIM.
- (5) Disconnect the aircraft battery and hang a placard "WARNING DO NOT CONNECT ELECTRICAL POWER" on the external power connection.
- (6) Remove the elevator units (Ref. AMM 55-21-11).
- (7) Remove access panels FB7 and FB8.
- (8) Open access panels FT2 and FT3 and disconnect the tension springs.
- (9) Remove the horizontal stabilizer (Ref. AMM 55-11-11).

PILATUS
PC-6
SERVICE BULLETIN

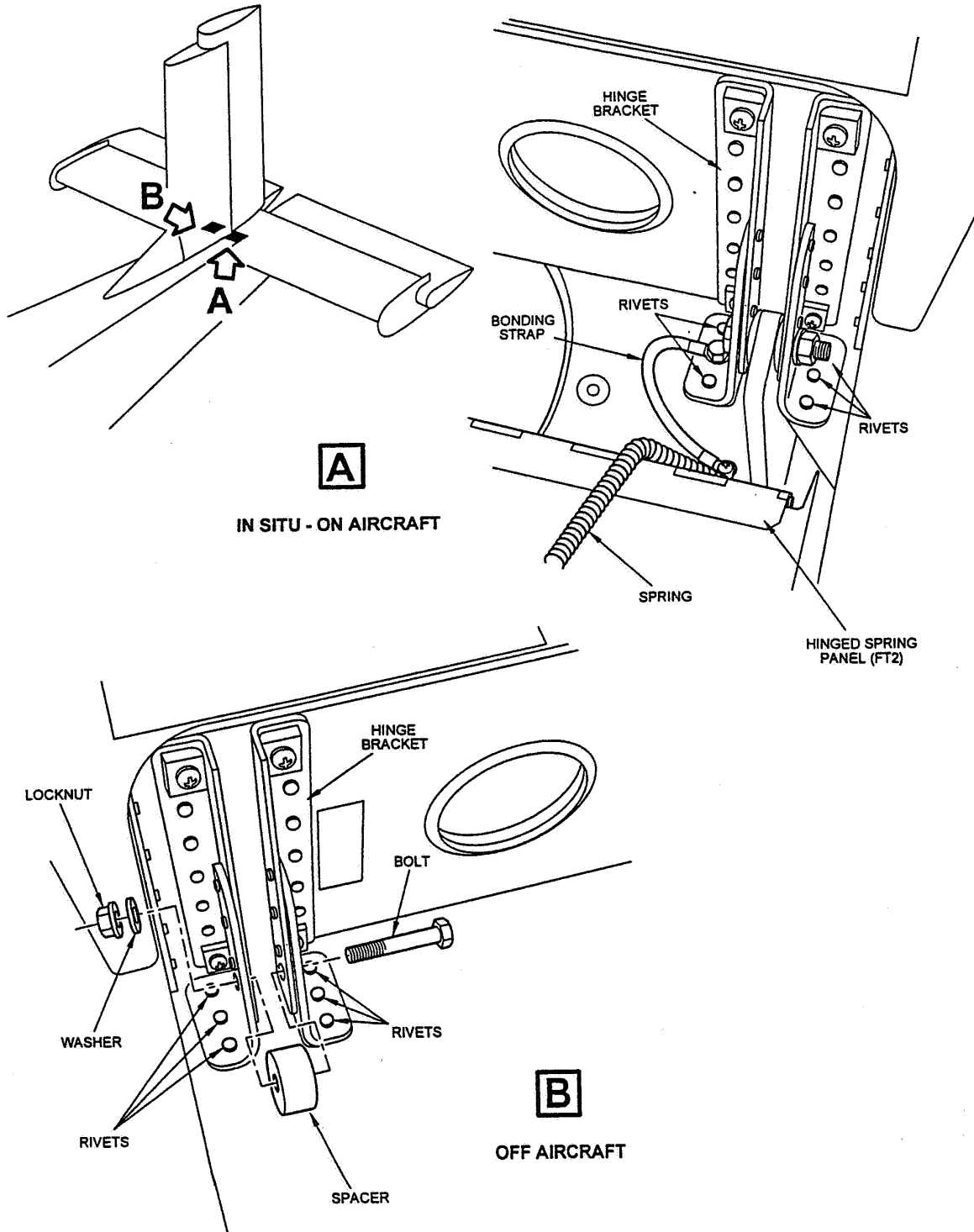

Repair Detail
Figure 1

DATE: FEB. 07/94
REVISION

SERVICE BULLETIN NO: PC-6 165
PAGE: 4 of 7

SB085

PILATUS
PC-6
SERVICE BULLETIN

- (10) Insert the 15 mm spacer, as shown in Figure 1, Detail B, and secure in position with the bolt.
- (11) When inserting the spacer, note the amount of force required to position the spacer.

NOTE: The spacer should not be able to displace or deflect the bracket. Where any force is needed to position the spacer then the bracket must be re-positioned.

When either one of the brackets is found to out off tolerance, then both brackets must be re-positioned

D. Modification

- (1) Drill out all indicated rivets from the respective hinge bracket (Ref. Fig. 1).
- (2) Assemble the hinge bracket with the new spacer and secure together with the bolt, washer and locknut.
- (3) Torque-tighten the locknut to 14.7 Nm (130 lbf in).
- (4) Drill one hole in the hinge bracket and insert a grip pin.
NOTE: All holes to be drill 4.1 mm dia.
- (5) Drill out the opposite hole and insert a grip pin.
- (6) Drill all other holes.
- (7) Deburr, clean and restore surface finish (Ref. SRM 51-00-06)
- (8) Rivet the holes.
- (9) Remove both grip pins.
- (10) Deburr, clean and restore surface finish (Ref. SRM 51-00-06) of the two holes and then rivet.
- (11) Remove nut, washer and bolt and 15 mm spacer.
- (12) Repeat steps 1 thru 11 on the other hinge bracket.
- (13) Repair paint scheme (Ref. SRM 51-00-06).

≡PILATUS≡
PC-6
SERVICE BULLETIN

E. Close-Up

- (1) Install the horizontal stabilizer (Ref. AMM 55-11-11).
- (2) Install the elevators (Ref. AMM 55-21-11).
- (3) Rig the horizontal stabilizer (Ref. AMM 27-40-00).
- (4) Rig the elevator controls (Ref. AMM 27-30-00).
- (5) Connect the tension springs and close access panels FT2 and FT3.
- (6) Install access panels FB7 and FB8.
- (7) Connect the aircraft battery and remove the WARNING placard from external power connection.
- (8) Remove safety clip and close the circuit breaker STAB TRIM.

≡PILATUS≡
PC-6
SERVICE BULLETIN

3. MATERIAL INFORMATION

A. List of Components

Modification of one aircraft requires the following rivets:

Description:	Part Number:	Qty:
Rivets (Dia. 4 mm x 11 mm long)	939.13.81.327	11