



SERVICE BULLETIN

DATE: December 1972

NO: 118

Page 1 of 7

Inboard Fuel Tank Vent System

1. Planning Information

1.1 Effectivity

- Models: All models PC-6 series.
- Serial Nos.:
PILATUS production:
No. 338 to 736.
FAIRCHILD INDUSTRIES production:
not applicable.

1.2 Reason: Introduction of an improved inboard fuel tank ventilating system, which is less susceptible to icing and provides symmetrical fuel feed in the event of clogged vent valves.

1.3 Description: Replacement of the existing inboard fuel tank 1/4" vent piping and stand pipe fairing.

1.4 Compliance: Optional.

1.5 Approval: Approved by the Swiss Federal Air Office.

1.6 Man Power: Approximately 12 man hours are required to carry out the modification.

1.7 Material, Cost and Availability: The material listed in para. 3 is available from PILATUS. Price and delivery information on request.

- 1.8 Tooling: No special tools required.
- 1.9 Weight and Balance: Increase in weight and moment is negligible.
- 1.10 Reference to other Publication: - Parts Catalogue Fig. 7 or Fig.1/1/23 and Fig. 121 or Fig. 5/5/5.
- PILATUS Service Bulletin No. 12B.
- PILATUS Service Letter No. 007.

2. Accomplishment Instruction

2.1 Preliminaries

- Drain both fuel tanks.
- Remove the inboard tank access cover on both sides.
- Remove the fairing covering the fuel feeder line on both wing root ribs.
- Remove the upper fairing panels left- and right-hand in the cabin.
- Open the access zip fastener in the cabin ceiling.
- Partially remove the wing-fuselage gap sealing tape on the upper side to provide access for tubing removal and reinstallation.

2.2 Removal of Existing Piping (Fig. 1)

- Remove stand pipe fairing.
(Attachment screws may be reused)
- Disconnect the tubing at the central T-fitting and at the tank wall fittings and remove all parts.
- Drill out the riveted flange of the vent fitting in both root ribs, using an extended drill of 0.094 in. dia.
- Cut the sealing compound around the flange and remove the fitting.

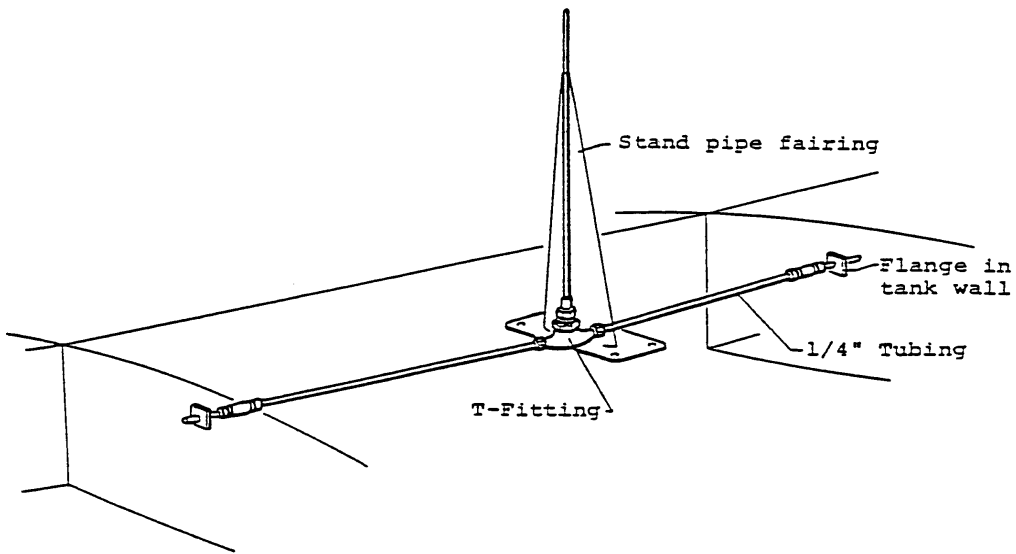

Fig. 1 Existing version of inboard fuel tank vent system

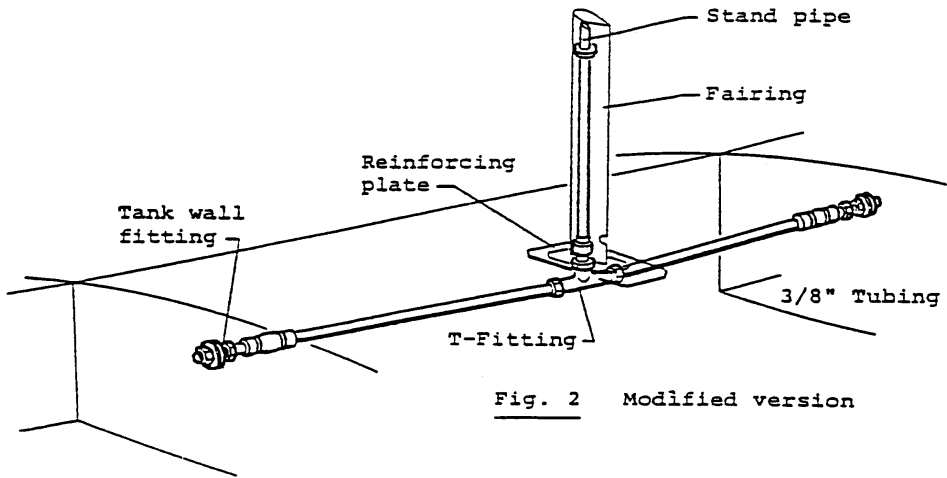

Fig. 2 Modified version

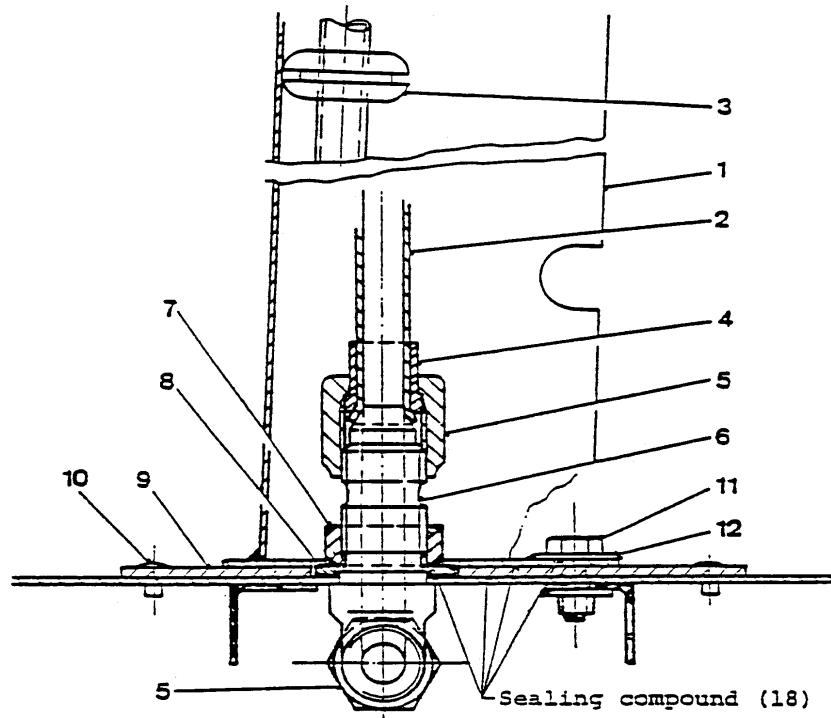

Fig. 3 Stand pipe lead-in and fairing attachment

Item Nos. refer to Material List para. 3

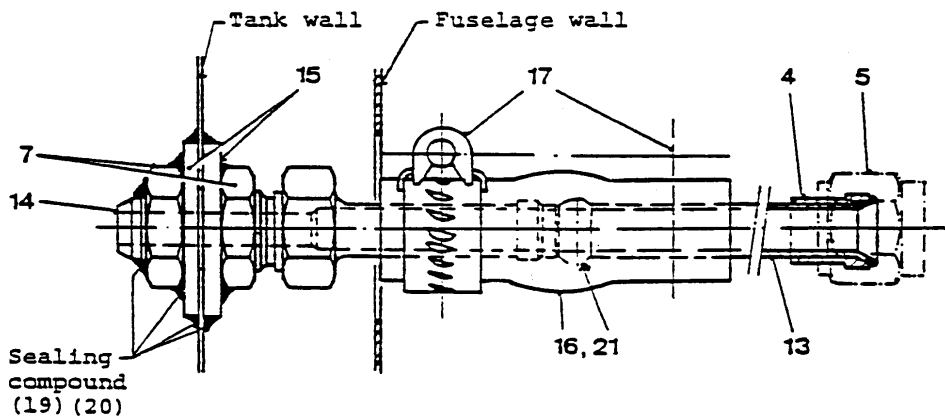

Fig. 4 Tank wall insertion

2.3 Rework (Fig. 3 and 4)

(Item Nos. refer to material list and sketches)

- Enlarge the hole in the fuselage wall to 1.34 in. dia. each side (Fig. 4).
- Enlarge the hole in the root rib (fuel tank wall) to 0.57 in. dia. and completely clean the inner surface within approx. 1.6 in. dia. of residual sealing compound, to obtain proper contact surfaces for the new fittings (Fig. 4).
- Enlarge the hole in the cabin ceiling skin to 0.57 in. dia. (Fig. 3).
- Install the reinforcing plate (9) as illustrated in Fig. 3: center the plate with the existing attachment screws (11), drill rivet holes and rivet the plate in position; apply sealing compound (18) to the contact surfaces prior to riveting.

2.4 Installation of New Vent System

- Install the vent fitting in both root ribs as illustrated in Fig. 4. Apply sealing compound (19) to the cleaned washers (15) surfaces, install the nuts and coat the parts with sealing compound (19) with two or three layers. Following a curing period of at least 24 hours, apply protective coating (20) with two layers. Allow to dry for approx. 6 hours between layers.
- Install rubber sleeves (16), 3/8" lines (115.55.06.232) and T-fitting (6); apply sealing compound (18) to the washer (8) when installing the T-fitting and use a lubricant (21) when installing the rubber sleeves.
- Install the stand pipe (115.55.06.208), ensure the grommet (3) is properly bonded to the upper section of the tube.
- Install the fairing (1) using sealing compound (18) to the flange surface and to the screws and washers in order to prevent contact corrosion.

2.5 Final Work

- Remove all swarf and foreign matter from the fuel tanks.
- Approx. 24 hours after protective coat application reinstall the tank access covers and refuel.
- Inspect newly installed fittings for leaks during several hours.
- Renew the fuselage wing gap sealing tape within the interrupted area. See PILATUS Service Letter No. 007.
- Apply outside paint to the new stand pipe fairing and reinforcing plate.

Note

If these parts have been painted prior to assembly, only the rivet and screw heads should finally be coated.

- Reinstall fairing panels.
- Note compliance with this Bulletin in the aircraft log book.

3. Material Information

Item No.	New P/N	Qty.	Keyword	Old P/N	Disp.
1	115.55.06.206√	1	Stand pipe fairing	6238.0076.00	discard
2	115.55.06.210*	1	Stand pipe	6238.0080.00	discard
3	944.87.31.011*	1	Grommet	-	-
4	946.29.95.505*	3	Sleeve	-	-
5	946.29.95.205*	3	Union nut	-	-
6	946.23.65.555	1	T-fitting	946.23.65.553	discard
7	946.29.94.022	5	Nut	946.29.94.020	discard
8	938.78.11.112	1	Washer	6238.0070.16	discard
9	115.55.06.209	1	Reinforcing plate	-	-
10	939.16.81.252	14	Rivet	-	-
11	932.03.44.015	4	Screw	932.03.44.015	reuse
12	938.78.13.104	4	Washer	938.78.13.104	reuse
13	115.55.06.233*	2	Tube	6238.0070.04	discard
14	946.20.15.502	2	Fitting	-	-
15	115.55.06.231	4	Washer	-	-
16	917.97.38.005	2	Rubber sleeve	6236.0070.39	discard
17	946.33.21.101	4	Hose clamp	946.33.21.101	reuse
18	907.13.11.902		Sealing compound (Hylomar SQ32 L or M or similar product)	-	-
19	907.13.13.022		Sealing compound MIL-S-8802 Class A (EC-1675 Class A or equivalent product)	-	-
20	910.33.88.214		Protective coating MIL-C-27725 (PR-1560 or equivalent product)	-	-
21	908.20.02.047		Lubricant ("Hellerine" or similar product)	-	-

*) Shown in subassembly Dwg. No. 115.55.06.208 and No. 115.55.06.232.

Ru/js

PILATUS AIRCRAFT LTD.