

SERVICE BULLETIN

SERVICE BULLETIN NO: 27-001

REF NO: 184

MODIFICATION NO:

ATA CHAPTER: 27

FLIGHT CONTROLS - AILERON CONTROLS BELLCRANK ASSEMBLIES - INSPECTION AND REPLACEMENT OF BEARING HOUSINGS

1. Planning Information

A. Effectivity

- (1) All PC-6 aircraft up to and including MSN 939.
- (2) All bellcrank assemblies P/N 6132.0071.51, 6132.0071.52 and 6232.0118.00 held as spare.

B. Concurrent Requirements

None.

C. Reason

(1) Problem

Unwanted axial movement of bellcrank assemblies (P/Ns 6132.0071.51, 6132.0071.52 and 6232.0118.00) can occur in the aileron control systems of PC-6 aircraft. The unwanted movement can cause the heads of the control cable attachment bolts to catch on the adjacent structure.

(2) Cause

The unwanted movement occurs if the bearings (P/Ns 940.83.18.301 and 940.83.18.303) become loose in the bearing housings (housings) of bellcrank assemblies. This is caused by deterioration of the bond between the surfaces of the bearings and their housings.

(3) Solution

- (a) Do a one time inspection of the aileron bellcrank assemblies P/Ns 6132.0071.51 and 6132.0071.52:
 - There are two variants of bearing installation, one with circlips installed and one without circlips installed. Assemblies without circlips must be modified to stake the bearing in the housing. This modification is not applicable to bellcranks with circlips installed.
 - Do a check of the cable attachment bolts for the correct length. Change all bolts that are not the correct length.
- (b) Install the fuselage bellcrank assembly (P/N: 6232.0118.00) so that surface of the bellcrank with the flange of the housing is adjacent to Frame 3. The effect of this is to lock the bellcrank on the bearing tube and thus prevent movement.

≡PILATUS≡
PC-6
SERVICE BULLETIN

D. Description

This Service Bulletin gives the data and instructions necessary to:

- Do a one time inspection of the bellcrank assemblies (before removal) to identify which have a circlip installed
- Remove the bellcrank assemblies
- Do a one time inspection of the bellcrank assemblies for loose or worn bearings
- Do a one time inspection of the control-cable attachment bolts for correct type and for signs of rub damage
- Stake and lock the bearing in the housings of the wing bellcranks (6132.0071.51) and (6132.0071.52)
- Install the bellcrank assemblies

Temporary Revision 27-01 to the IPC is included in this Service Bulletin (Ref. Appendix A). Its purpose is to show the Post-Service Bulletin 27-001 installation of the fuselage bellcrank.

E. Compliance

Mandatory.

Required within the next 100 hours time-in-service (TIS) or three months after the effective date of this Service Bulletin, whichever occurs first.

F. Approval

The technical aspects of this Service Bulletin have been approved by the Federal Office for Civil Aviation (FOCA) of Switzerland as an Airworthiness Directive.

PILATUS advises Operators/Owners to check with their local Airworthiness Authorities for any changes, local regulations or sanctions that may affect the embodiment of this Service Bulletin.

G. Manpower

	Total
Preparation	1.5
Modification	4.5
Close up	1.0
TOTAL MAN-HOURS	7.0

H. Weight and Balance

(1) Weight Change

Not affected.

(2) Moment Change

Not affected.

≡PILATUS≡
PC-6
SERVICE BULLETIN

I. Electrical Load Data

Not changed.

J. Software

Not changed.

K. References

Aircraft Maintenance Manual (AMM), 06-40-00, 20-00-00, 20-10-01 and 27-10-00.

Illustrated Parts Catalog (IPC), 25-13-01.

L. Publications Affected

IPC, 27-12-01.

M. Interchangeability of Parts

Pre and Post SB 27-001 are fully interchangeable.

2. Material Information

A. Material Necessary for Each Aircraft

Part Numbers, given in this Service Bulletin, are correct at the time of approval. PILATUS AIRCRAFT LTD. reserves the right to change part numbers as necessary

(1) Material to be Purchased.

Not applicable. Modification kit not necessary.

(2) Additional Material to be Purchased

Part No.	Description	Qty	Remarks
940.17.02.212	Pin - Cotter	6	MS24665-69
940.17.02.225	Pin - Cotter	2	MS24665-132
940.17.02.325	Pin - Cotter	2	DIN94/1*16

(3) Operator Supplied Materials

Part No.	Description	Qty	Remarks
8010-0-100-012P	Paint - Primer	A/R	Item No. P07-007
908.20.02.063	Grease (MIL-G23827B)	A/R	Item No. P04-002
908.40.32.251	Corrosion Preventative (Alodine 1200S)	A/R	Item No. P07-001
919.01.11.104	Wire - Locking (0,8 mm Dia)	A/R	Item No. P02-001

PILATUS
PC-6
SERVICE BULLETIN

B. Material Necessary for Each Spare

(1) Material to be Purchased

Not applicable.

(2) Additional Material to be Purchased

Not applicable.

(3) Operator Supplied Materials

Part No.	Description	Qty	Remarks
8010-0-100-012P	Paint - Primer	A/R	Item No. P07-007
908.40.32.251	Corrosion Preventative (Alodine 1200S)	A/R	Item No. P07-001

C. Reidentified Parts

Not applicable

D. Tooling - Cost and Availability

Part No.	Description	Cost	Availability
110.85.06.105	Staking and Locking Tool - Bearing. Contains: <ul style="list-style-type: none">• Die (1 off)• Pin (3 off)• Washer (1 off)	CHF 450	Available on application to PILATUS

≡PILATUS≡
PC-6
SERVICE BULLETIN

3. Accomplishment Instructions - Aircraft

WARNING: BE CAREFUL WHEN YOU USE THE CONSUMABLE MATERIALS. OBEY THE MANUFACTURERS HEALTH AND SAFETY INSTRUCTIONS.

A. Preparation

- (1) Install the internal flight-control locks or the external aileron locks as necessary.
- (2) Put a warning sign (DO NOT OPERATE THE FLIGHT CONTROLS) in the flight compartment.
- (3) Remove access panels LB14 and RB13 (Ref. AMM, 06-40-00, Page Block 1).
- (4) Remove the corner, ceiling liner and fairing panels from the left side of the cockpit (Ref. IPC, 25-13-01, Fig. 01).
- (5) Use a light source and mirror to do an inspection of the bellcranks (11/12, Fig. 1) and (10, Fig. 2) to identify if the housings (5, Fig. 1) and (8, Fig. 2) have circlips (P/N N237) installed. The circlips prevent axial movement of the bellcranks on their bearings. It is not necessary to do the procedures given in Paras. B thru E if you find circlips installed.
- (6) Do an inspection of the bellcrank (10, Fig. 2) for correct installation. The bellcrank is installed correctly if the surface with the flange of the housing (8) is to the rear.

NOTE: It is possible for the bellcrank (10) to be installed with the surface (which has the flange of the housing (8)) to the front or to the rear.

B. Removal of the Bellcrank Assemblies

Paras. B thru E are only applicable to bellcrank assemblies without circlips (P/N N237) installed.

- (1) Loosen the control cables of the left aileron (Ref. Fig. 1).
 - (a) Remove and discard the lock wire from the turnbuckles (7).
 - (b) Turn the turnbuckles (7) until the control cables (8) are loose.
- (2) Remove the left aileron bellcrank.
 - (a) Remove and discard the cotter pins (10), (14) and (17).
 - (b) Remove the nuts (9) and bolts (6) to disconnect the fork ends of the turnbuckles (7) from the bellcrank (11).
 - (c) Remove the nut (13) and bolt (16) to disconnect the fork end of the control rod (15) from the bellcrank (11).
 - (d) Remove the nut (18), bolt (1) and washers (2) to disconnect the bellcrank (11) from the support plates (3) and (4).
- (3) Do Step (1), (a) & (b) and Step (2), (a) thru (d) again to remove the right aileron bellcrank (12).

PILATUS
PC-6
SERVICE BULLETIN

- (4) Remove the bellcrank from the fuselage (Ref. Fig. 2). This step is only applicable if the surface of the bellcrank which has the flange of the housing (8) is installed to the front (Ref. Para A, Step (5)).
 - (a) Remove and discard the lock wire from the turnbuckles (12).
 - (b) Turn the turnbuckles (12) until the control cables (6) are loose.
 - (c) Remove and discard the cotter pins (3).
 - (d) Remove the nuts (2), washers (1) and bolts (7) to disconnect the fork ends of the control cables (6) from the bellcrank (10).
 - (e) Remove the nut (2), washer (1) and bolt (11) to disconnect the bellcrank (10) from the push rod assembly (4).
 - (f) Remove the circlip (9) from the bearing tube (5).
 - (g) Turn the bellcrank (10) until the top is clear of the push rod assembly (4). Pull the bellcrank to remove it from the bearing tube (5).

C. Inspection

- (1) Do an inspection of the wing bellcranks and related components (Ref. Fig. 1).
 - (a) Do an inspection of the housings (5) for wear, damage and signs of axial movement of the bearings in the housings. Worn or damaged bearings are not permitted. Axial movement of serviceable bearings in the housings is permitted (Ref. Para D).
 - (b) Do an inspection of the bolts (6) for signs of rub damage on the heads. No damage is permitted.
 - (c) Do a check of the bolts (6) for correct length. Discard bolts that have a total length of more than 21,5 mm (0.85 in.).

NOTE: It is not sufficient to do a check of the bolt part numbers. This is because it is possible for bolts of different lengths to have the same identification.
 - (d) Do an inspection of the support plate (3) for signs of rub damage caused by the bolts (6). Apply to PILATUS for repair instructions if you find damage.
- (2) Do an inspection of the housing (8, Fig. 2) for wear, damage and signs of axial movement of the bearing in the housing. A worn or damaged bearing is not permitted. Apply to PILATUS for a repair procedure if you find signs of axial movement of a bearing in the housing.

D. Stake and Lock the Bearings in the Housings (Ref. Fig. 3)

This procedure is applicable to all (wing) bellcrank assemblies (4) and (5) with or without axial movement of the bearings in the housings (Ref. Para C, Step (1), (a)).

- (1) Make sure the three pins (2) are removed from the die (1).
- (2) Put a washer (6) and the left bellcrank (4) in position on a bearing press (or equivalent) as shown. Make sure the washer is concentrically aligned with the end of the bearing (3).
- (3) Put the die (1) in position on the remaining end of the bearing (3).

≡PILATUS≡
PC-6
SERVICE BULLETIN

- (4) Operate the bearing press to push the bearing (3) fully into the housing (7).
- (5) Remove the die (1).
- (6) Put the three pins (2) in position in the die (1).
- (7) Put the die (1) in position on the open end of the housing (7).
- (8) Operate the bearing press until the die (1) stops against the bearing. Do this to bend the rim of the housing (7) at three places and thus, lock the bearing (3) in position.
- (9) Apply the surface protection to the bare metal areas on the rim of the housing (7).
 - (a) Obey the manufacturers instructions and apply layers of corrosion preventative (Item No. P07-001) on the bare surfaces. Do this at the three positions on the rim of housing (7).
 - (b) Obey the manufacturers instructions and apply layers of primer paint (Item No. P07-007). Do this at the three positions on the rim of housing (7).
- (10) Do Steps (2) thru (9) again to stake and lock the bearing (3) in the housing (7) of the right bellcrank (5).

E. Installation of the Bellcrank Assemblies

- (1) Install the left aileron bellcrank (Ref. Fig. 1).
 - (a) Obey the manufacturers instructions and apply a thin layer of the grease (Item No. P04-002) on the applicable surfaces of the bolts (2), (6) and (15).
 - (b) Put the left bellcrank (11) in position between the support plates (3) and (4).
 - (c) Put the washer (2) on the bolt (1).
 - (d) Put the bolt (1) in position through the support plates (3) & (4) and the bellcrank (11).
 - (e) Put the remaining washer (2) on the bolt (1) and install the nut (18).
 - (f) Install the new cotter pin (17) in the bolt (1) (Ref. AMM, 20-10-01, Page Block 201).
 - (g) Put the fork end of the control rod (15) in position on the bellcrank (11).
 - (h) Put the bolt (16) in position through the fork end of the control rod (15) and the bellcrank (11) then install the nut (13).
 - (i) Install the new cotter pin (14) in the bolt (16) (Ref. AMM, 20-10-01, Page Block 201).
 - (j) Put the fork ends of the turnbuckles (7) in position on the bellcrank (11).
 - (k) Put the bolts (6) in position through the fork ends of the turnbuckles (7) and the bellcrank (11) then install the nuts (9).
 - (l) Install the new cotter pins (10) in the bolts (6) (Ref. AMM, 20-10-01, Page Block 201).

≡PILATUS≡
PC-6
SERVICE BULLETIN

- (2) Do Step (1), (a) thru (k) again to install the right aileron bellcrank (12).
- (3) Tighten and tension the left and right aileron control cables (8) (Ref. AMM, 27-10-00, Page Block 501).
- (4) Safety the turnbuckles (7) with lock wire (Ref. AMM, 20-10-01, Page Block 201).
- (5) Install the bellcrank in the fuselage (Ref. Fig. 2).
 - (a) Obey the manufacturers instructions and apply a thin layer of the grease (Item No. P04-002) on the applicable surfaces of the bolts (7), (11) and bearing tube (5).
 - (b) Put the bellcrank (10) in position on the bearing tube (5). When you do this turn the bellcrank around through 180° on its pivot axis. Do this to make sure that its position on the bearing tube is opposite (180°) to its initial position.
 - (c) Install the circlip (9) on the bearing tube (5) (Ref. AMM, 20-10-01, Page Block 201).
 - (d) Align the top bearing in the bellcrank (10) with the applicable bolt hole in the push rod assembly (4). Put the bolt (11) in position.
 - (e) Put the washer (1) on the bolt (11) and install the nut (2).
 - (f) Install a new cotter pin (3) in the bolt (11) (Ref. AMM, 20-10-01, Page Block 201).
 - (g) Put the fork ends of the control cables (6) in position on the bellcrank (10).
 - (h) Put the bolts (7) in position through the fork ends of the control cables (6) and the bellcrank (10).
 - (i) Put a washer (1) on each of the bolts (7) and install the nuts (2).
 - (j) Install the new cotter pins (3) in the bolts (7) (Ref. AMM, 20-10-01, Page Block 201).
 - (k) Tighten and tension the aileron control cables (6) (Ref. AMM, 27-10-00, Page Block 501).
 - (l) Safety the turnbuckles (6) with lock wire (Ref. AMM, 20-10-01, Page Block 201)
- (6) Remove the internal and external flight control locks.
- (7) Remove the warning sign from the flight compartment.
- (8) Do the aileron control-system adjustment/test procedure (Ref. AMM, 20-00-00, Page Block 201 and 27-10-00, Page Block 501).

≡PILATUS≡
PC-6
SERVICE BULLETIN

F. Close up

- (1) Remove all tools and materials. Make sure the work areas are clean.
- (2) Install the access panels LB14 and RB13 (Ref. AMM, 06-40-00, Page Block 1).
- (3) Install the corner, ceiling liner and fairing panels in the cockpit (Ref. IPC, 25-13-01, Fig. 01).

G. Documentation

- (1) Make an entry in the Aircraft Logbook that this Service Bulletin has been incorporated.

4. Accomplishment Instructions - Spares

A. Inspection (Ref. Fig. 1 and 2)

- (1) Do an inspection of the bellcrank assemblies (11/12, Fig. 1) and (10, Fig. 2) to identify the housings (5, Fig. 1) and (8, Fig. 2) that have circlips (P/N N237) installed. This item prevents axial movement of the bearings. It is not necessary to do the procedures given in Paras B and C if you find circlips installed.

B. Lock the Bearings in the Housings (Ref. Fig. 3)

Paras. B and C are only applicable to bellcrank assemblies (4) and (5) without circlips (P/N N237).

- (1) Make sure the three pins (2) are installed the die (1).
- (2) Put the die (1) in position on the open end of the housing (7).
- (3) Operate the bearing press to bend the rim of the housing (7) at three places and lock the bearing (3) in position.
- (4) Apply the surface protection to the bare metal areas on the rim of the housing (7).
 - (a) Obey the manufacturers instructions and apply layers of corrosion preventative (Item No. P07-001) on the bare surfaces. Do this at the three positions on the rim of housing (7).
 - (b) Obey the manufacturers instructions and apply layers of primer paint (Item No. P07-007). Do this at the three positions on the rim of housing (7).
- (5) Do Steps (1) thru (4) again to lock the bearing (3) in the housing (7) of the right bellcrank (5).

C. Documentation

- (1) Make an entry in the spare parts inventory list that this modification has been incorporated.

PILATUS PC-6 SERVICE BULLETIN

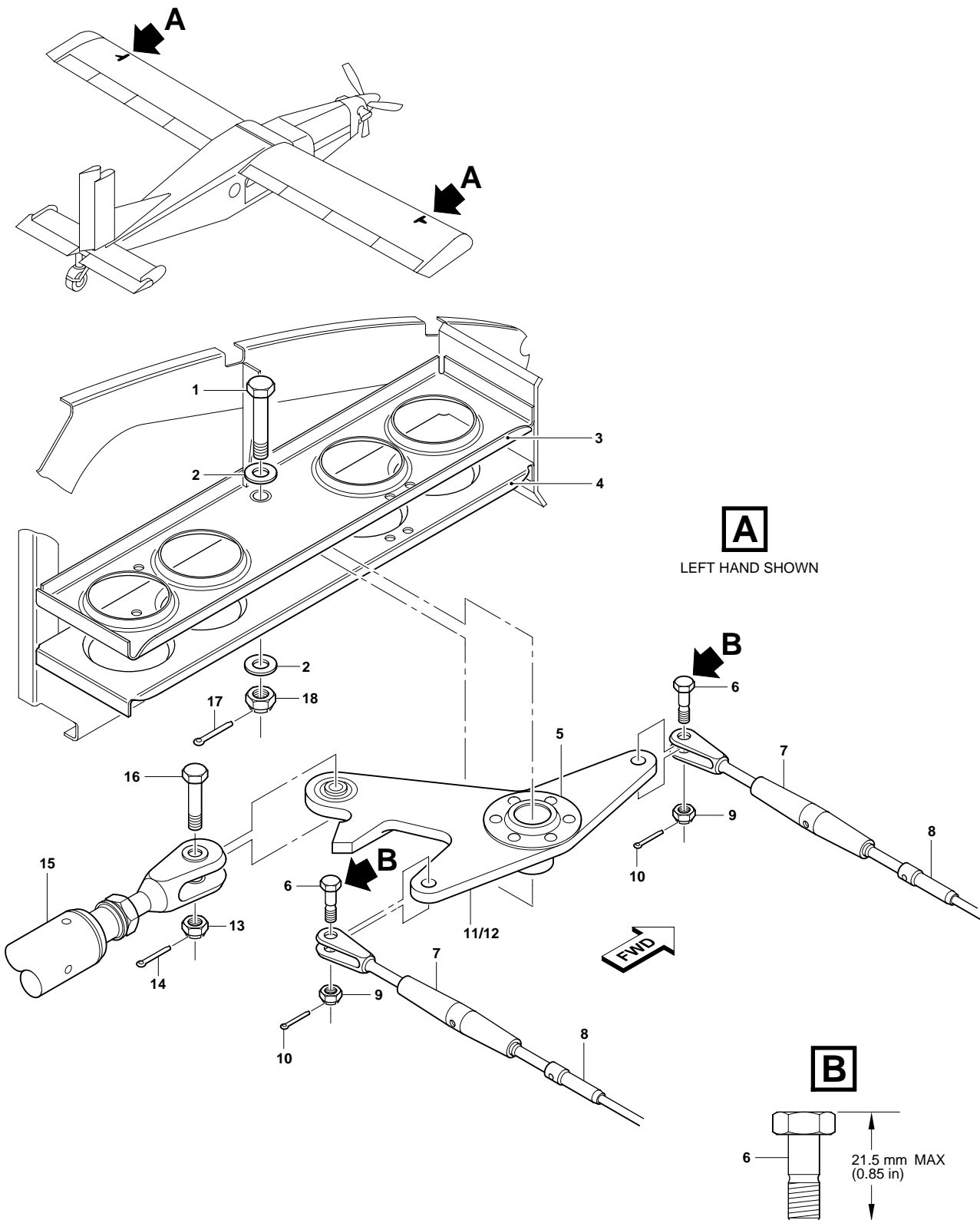

SB1146

Wing Bellcrank and Housing Assemblies - Inspection and Replacement
Figure 1

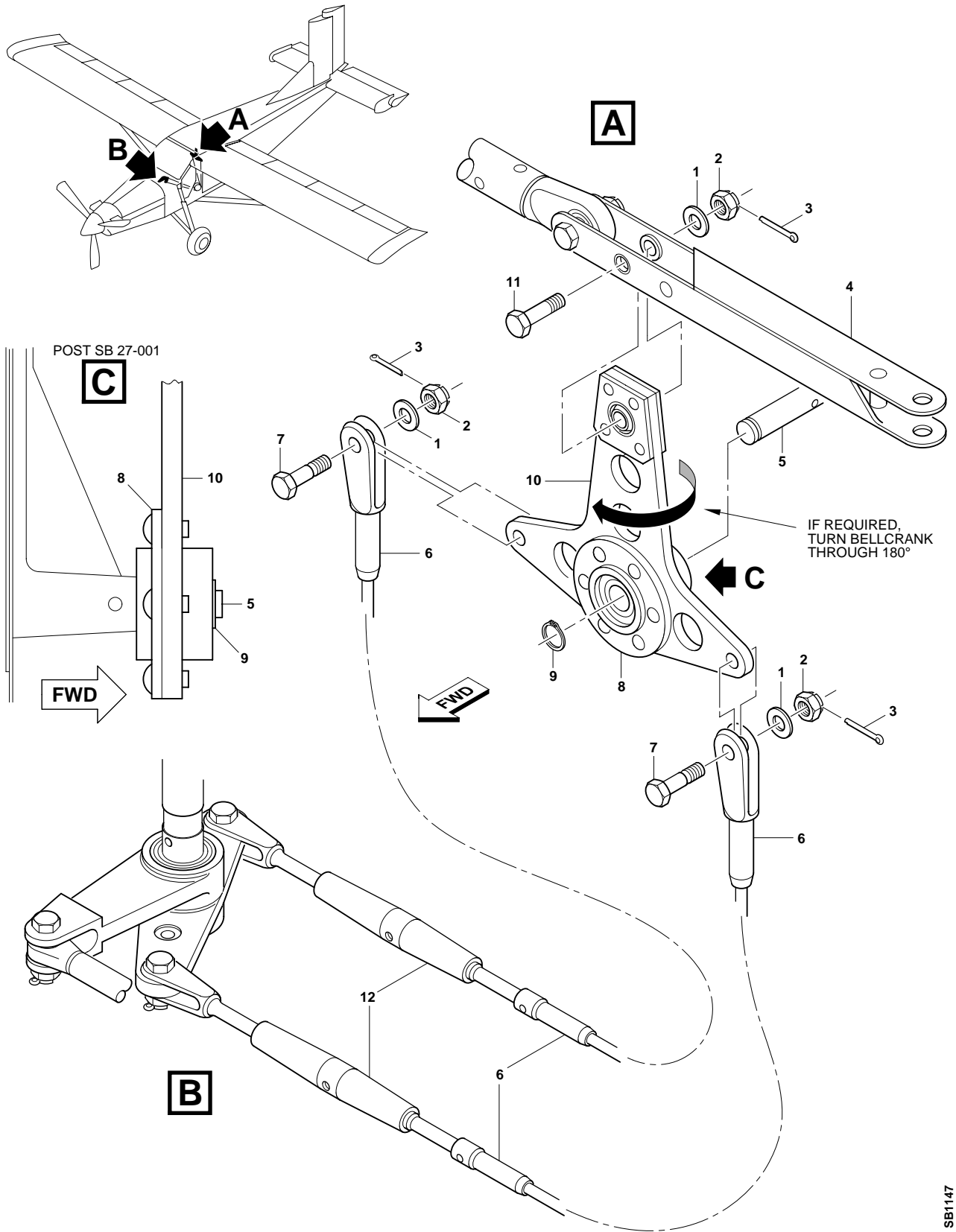

PC-6
SERVICE BULLETIN



Fuselage Bellcrank and Housing Assembly - Inspection and Installation
 Figure 2

SB1147

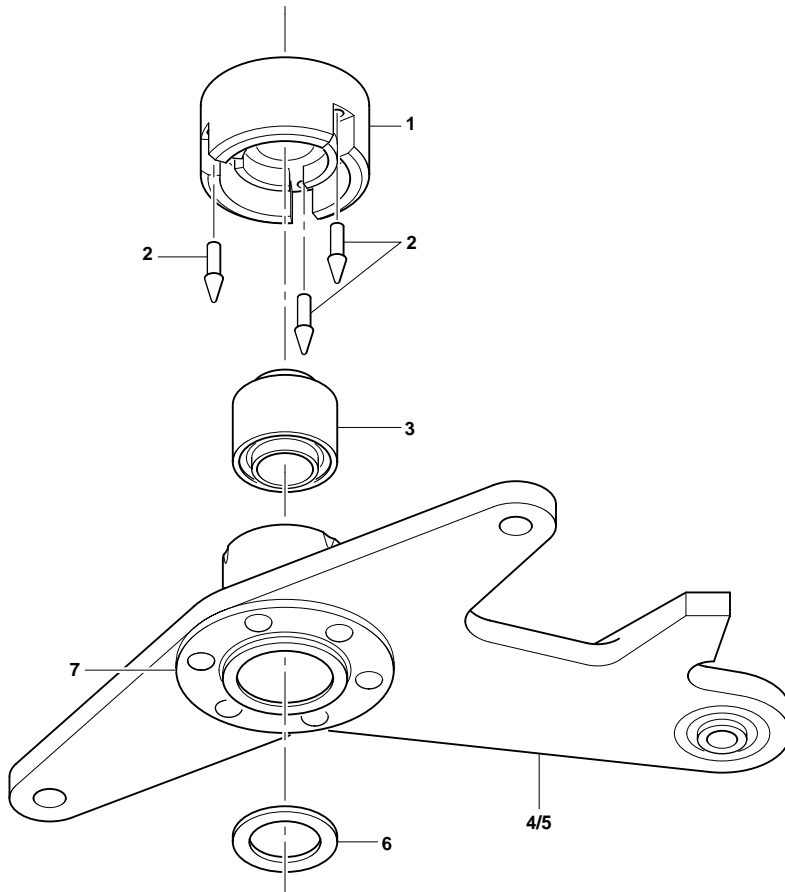
PILATUS
PC-6
SERVICE BULLETIN



SB1148

Bellcrank Assemblies (Wing) - Staking and Locking of the Bearings
Figure 3

≡PILATUS≡
PC-6
SERVICE BULLETIN

APPENDIX A:

IPC TEMPORARY REVISION 27-01

≡PILATUS≡
PC-6
SERVICE BULLETIN

INTENTIONALLY BLANK

TEMPORARY REVISION No. 27-01

Date: 05/06/02

Filing Instructions:

Insert the following page as close as possible to your existing Aileron Control Instln. Figure.

Important:

Do not remove this Temporary Revision unless instructed to do so by:

- The Highlights of a Normal Revision.
- A new Temporary Revision which supersedes this one.

Reason for Issue:

SB 27-001 requires the fuselage bellcrank to be turned 180°. It is therefore necessary to show the change to the existing figure for the bellcrank installation.

Aileron Bellcrank Part Number 6232.0118.00 amended.

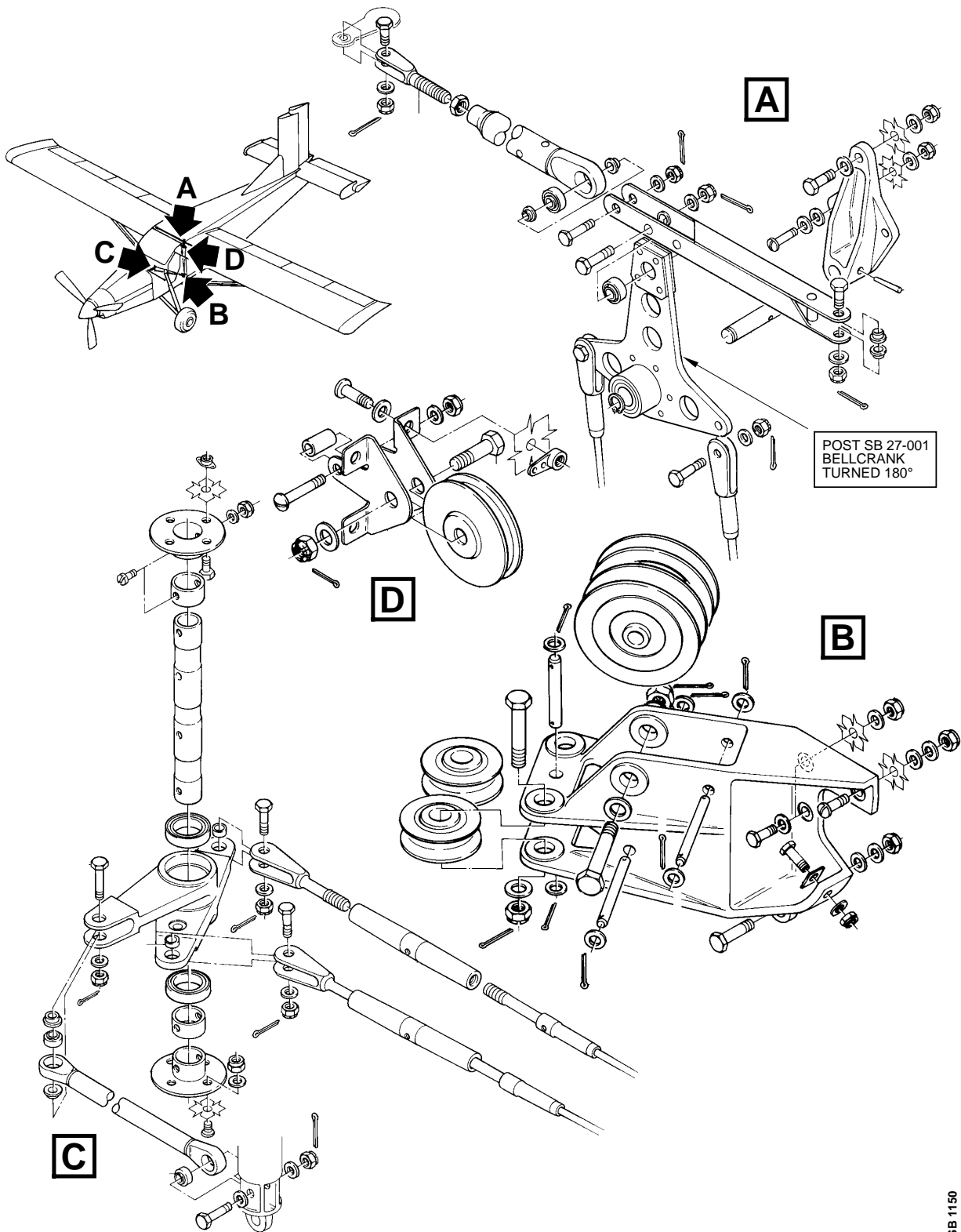

Aileron Control Instl, Fuselage
Figure 01 (Unannotated)